



# CHAPTER 3

## **BRAKING COMPONENT CONFIGURATION AND WIRING**

---

### TABLE OF CONTENTS

<i>Operational Electrical Information</i> . . . . .	3-2
<i>Overload Relay</i> . . . . .	3-2
<i>Dynamic Braking Unit Setup</i> . . . . .	3-3
<i>DBU Jumper and Wiring Terminal Locations</i> . . . . .	3-3
<i>DBU Voltage Jumper Settings</i> . . . . .	3-4
<i>DBU Master/Slave Jumper Settings</i> . . . . .	3-5
<i>Dynamic Braking Wiring</i> . . . . .	3-6
<i>Wiring Warnings and Notes</i> . . . . .	3-6
<i>Maximum Wiring Distances</i> . . . . .	3-7
<i>Dynamic Braking Unit Wiring Terminals</i> . . . . .	3-7
<i>Basic Braking Wiring Diagram</i> . . . . .	3-9
<i>Specific Braking Wiring Diagrams</i> . . . . .	3-10

## OPERATIONAL ELECTRICAL INFORMATION

The *DURAPULSE* AC Drive and Dynamic Braking Unit will both be energized at the same time when power is applied to the drive. (Please refer to the applicable *DURAPULSE* AC Drive User Manual (GS3\_UMW or GS4\_UMW) to determine the start and stop operation of the motor.) The Dynamic Braking Unit will monitor the internal DC bus voltage of the AC drive. When the AC drive stops the motor by decelerating, the braking unit will detect an increase in the drive's DC bus voltage due to the motor causing regeneration. The braking unit will then dissipate this excess energy into the braking resistor in the form of heat. Dissipating this regenerated energy will allow a stable and controlled deceleration of the motor.

The alarm relay output contact terminals (RC, RA, & RB) of the dynamic braking unit will be activated when the temperature of the braking unit heat sink exceeds 203°F (95°C) for DBUs ≤ 100hp, or 176°F (80°C) for DBUs > 100hp. This condition can be caused by the ambient temperature surrounding the braking unit exceeding 50°C (122°F), or by the Duty Cycle exceeding 10%. If this high ambient temperature situation exists, then a method of reducing the ambient temperature by the use of forced air cooling or some other means should be considered.

If the resistor does not have a temperature switch, install an overload relay between the DBU and the resistor.

## OVERLOAD RELAY

For safety purposes, install an external overload relay between the dynamic braking unit and the braking resistor. Wire the overload relay normally closed contact in series with the coil of a magnetic contactor to interrupt the power to the AC drive.

The purpose of installing the thermal overload relay is to protect the braking resistor from damage due to frequent braking, or due to the braking unit operating excessively due to unusually high input voltage.



---

*For overload relay selection information, refer to “Overload Relay Selection” in Chapter 1, page 1-5.*

---

## DYNAMIC BRAKING UNIT SETUP

### DBU JUMPER AND WIRING TERMINAL LOCATIONS

DBU ≤ 100hp (GS-1DBU, GS-2DBU, GS-3DBU, GS-4DBU)

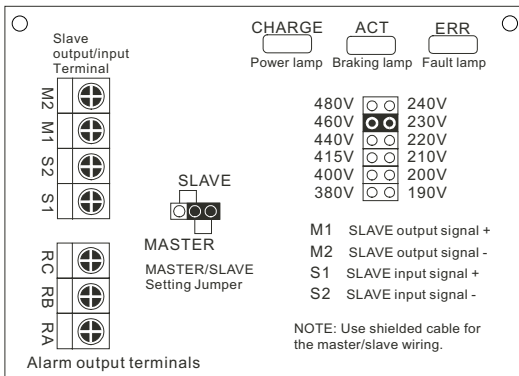

DBU > 100hp (GS-5DBU, GS-6DBU, GS-7DBU)

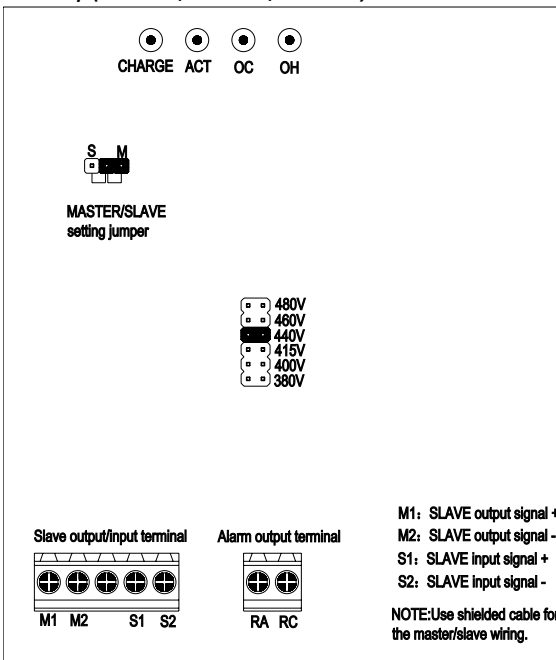

### DBU VOLTAGE JUMPER SETTINGS

The power source for the *DURApulse* dynamic braking unit is DC bus voltage from the +(P) and -(N) terminals of the GS drive. It is important to set the voltage selection jumper of the *DURApulse* dynamic braking unit accurately based on the input power of the GS drive before operation. The voltage selection jumper setting determines the GS DC bus voltage level at which dynamic braking is applied.

*BEFORE SETTING THE VOLTAGE SELECTION JUMPER, MAKE SURE THE POWER HAS BEEN TURNED OFF. SET THE JUMPER TO MATCH THE HIGHEST POSSIBLE VOLTAGE FOR AN UNSTABLE POWER SYSTEM.*

*EXAMPLE: A 380VAC POWER SYSTEM RISES TO 410VAC ON A REGULAR BASIS. TO AVOID ENGAGING DYNAMIC BRAKING WHEN THE POWER SUPPLY VOLTAGE RISES ABOVE 380VAC, SET THE VOLTAGE SELECTION JUMPER TO THE 415VAC POSITION.*



For *DURApulse* AC drives, set the “Over Voltage Stall Prevention” parameter as “close (1)” to disable over-voltage stall prevention (P6.05 in GS3; P6.11 in GS4). This will ensure a stable deceleration characteristic.

BRAKING UNIT VOLTAGE SETTINGS					
MODELS ≤ 100HP (GS-1DBU, GS-2DBU, GS-3DBU, GS-4DBU)				MODELS > 100HP (GS-5DBU, GS-6DBU, GS-7DBU)	
230VAC CLASS		460VAC CLASS		460VAC CLASS	
AC POWER VOLTAGE	BRAKING START-UP VOLTAGE DC Bus (+(P), -(N)) VOLTAGE	AC POWER VOLTAGE	BRAKING START-UP VOLTAGE DC Bus (+(P), -(N)) VOLTAGE	AC POWER VOLTAGE	BRAKING START-UP VOLTAGE DC Bus (DC+,DC-) VOLTAGE
190 VAC	330 VDC	380 VAC	660 VDC	380 VAC	618 VDC
200 VAC	345 VDC	400 VAC	690 VDC	400 VAC	642 VDC
210 VAC	360 VDC	415 VAC	720 VDC	415 VAC	667 VDC
220 VAC	380 VDC	440 VAC	760 VDC	440 VAC	690 VDC
230 VAC	400 VDC	460 VAC	800 VDC	460 VAC	725 VDC
240 VAC	415 VDC	480 VAC	830 VDC	480 VAC	750 VDC

NOTE: Input Power With Tolerance ±10%

### DBU MASTER/SLAVE JUMPER SETTINGS

The MASTER/SLAVE jumper on the *DURAPULSE* dynamic braking unit has a factory default setting as a MASTER. If the application of the *DURAPULSE* AC drive requires the use of more than one DBU, then the power terminals of the multiple units are wired in parallel and the first unit is set to MASTER while all remaining units are set to SLAVE. The jumper settings along with the wiring between the MASTER/SLAVE (M1, M2, S1 & S2) terminals allows the multiple braking units to synchronize the power dissipation between braking units. This assures each unit is dissipating an equivalent amount of energy to allow rapid deceleration of the motor.

*Typical one-line wiring diagram for multiple parallel DURAPULSE dynamic braking units. The first DBU has the jumper set to MASTER, while the remaining DBUs are set to SLAVE. (DBU ≤ 100hp have terminals +(P) & -(N); DBU > 100hp have terminals DC+ & DC-)*

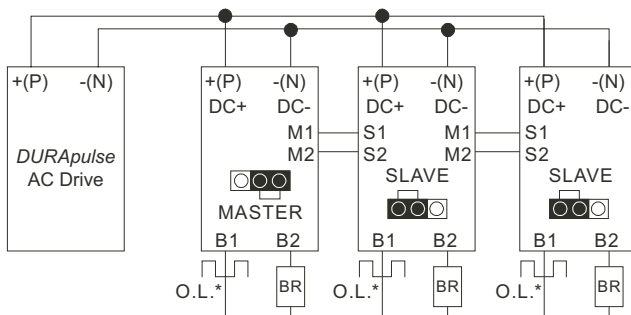

\* Although it is recommended, the use of a thermal overload relay in line with the braking resistor is not required. GS-xxxx-BR-ENC braking resistors include a thermostat for thermal protection of the braking resistor, and are the preferred method of protection when available. Orient the braking resistors such that the thermostat is above the resistors in the enclosure, as this will ensure that the thermostat is exposed to the rising air temperature produced by the resistors. Refer to the “Basic Braking Wiring Diagram” on page 3-9 for details.

## DYNAMIC BRAKING WIRING

### WIRING WARNINGS AND NOTES



DO NOT PROCEED WITH ANY WIRING WHILE POWER IS APPLIED TO THE CIRCUIT, OR WHILE THE DRIVE OR DBU CHARGE LED(s) ARE ON.



TO PREVENT PERSONAL INJURY, DO NOT CONNECT/DISCONNECT WIRES OR REGULATE THE SETTING OF THE BRAKING UNIT WHILE POWER ON. DO NOT TOUCH THE TERMINALS OF RELATED WIRING AND ANY COMPONENT ON PCB LEST USERS BE INJURED BY EXTREMELY DANGEROUS DC HIGH VOLTAGE.



CONFIRM THAT THE +(P) AND -(N) TERMINALS OF THE DURAPULSE AC DRIVE ARE PROPERLY CONNECTED TO THE DURAPULSE DYNAMIC BRAKING UNIT WITH THE CORRECT POLARITY BEFORE APPLYING POWER. OTHERWISE, THE DRIVE AND THE BRAKING UNIT COULD BE DAMAGED.



CONNECT THE BRAKING UNIT GROUND TERMINAL TO EARTH GROUND. THE GROUND LEAD MUST BE THE SAME GAUGE WIRE OR LARGER THAN LEADS +(P) AND -(N) OR DC+ AND DC-.



DO NOT WIRE TERMINALS -(N) OR DC- TO THE NEUTRAL POINT OF THE POWER SYSTEM.



DURING BRAKING, THE WIRES CONNECTED TO +(P), -(N), DC+, DC-, B1, AND B2 GENERATE POWERFUL ELECTROMAGNETIC FIELDS DUE TO HIGH CURRENT PASSING THROUGH. SEPARATE THESE WIRES FROM OTHER LOW VOLTAGE CONTROL CIRCUITS TO PREVENT ELECTRICAL INTERFERENCE OR IMPROPER OPERATION.



BEFORE WIRING THE RESISTOR(S) TO THE DYNAMIC BRAKING UNIT(S), CHECK THE MIN. RESISTOR VALUES SHOWN IN THE BRAKING COMPONENT SELECTION TABLES IN CH.1 OF THIS USER MANUAL, AND MAKE SURE THE ACTUAL RESISTANCE IS NO LESS THAN THIS VALUE. DAMAGE TO THE DYNAMIC BRAKING UNIT AND/OR RESISTORS AND OTHER EQUIPMENT CAN RESULT IF THE WRONG RESISTANCE VALUE IS USED.



FOR SAFETY PURPOSES, INSTALL AN OVERLOAD RELAY BETWEEN THE DYNAMIC BRAKING UNIT AND THE BRAKING RESISTOR. WIRE THE OVERLOAD RELAY NORMALLY CLOSED CONTACT IN SERIES WITH THE COIL OF A MAGNETIC CONTACTOR TO INTERRUPT THE POWER TO THE AC DRIVE TO PREVENT DAMAGE TO THE BRAKING RESISTOR IN THE CASE OF EXCESSIVE BRAKING OR UNUSUALLY HIGH INPUT VOLTAGE.

### MAXIMUM WIRING DISTANCES



WIRE SIZES AND WIRING DISTANCES MUST COMPLY WITH APPLICABLE ELECTRICAL CODES.

- From DURApulse AC Drive (GSx-xxxx) to Braking Resistor (GS-BR-xxxxxxx): 5m [16ft]
- From DURApulse AC Drive (GSx-xxxx) to DURApulse Dynamic Braking Unit (GS-xDBU): 10m [33ft]
- From DURApulse Dynamic Braking Unit (GS-xDBU) to Braking Resistor (GS-BR-xxxxxxx): 5m [16ft]

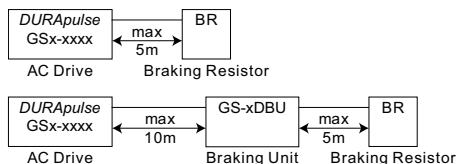

### DYNAMIC BRAKING UNIT WIRING TERMINALS



WIRE SIZES AND WIRING DISTANCES MUST COMPLY WITH APPLICABLE ELECTRICAL CODES.



Ring terminals are recommended to be used for main circuit wiring. Make sure the terminals are fastened before power is applied.

#### Ring Terminals

Ring terminals are not required by UL, but they can be used according to the UL conditions of acceptability.

#### UL Conditions of Acceptability

For use only in Industrial Control Equipment where the acceptability is determined by Underwriters Laboratories Inc.

This component controller has been judged on the basis of the required spacings in the Standard for Power Conversion Equipment, UL 508C, Pollution Degree 2.

The following shall be considered in the final application:

- 1) Terminals are acceptable for factory or field wiring.
- 2) Device shall be installed in a suitable enclosure.
- 3) Failure mode testing of the voltage sensing circuit, which could result in operation of the DC bus input at transient voltages higher than 800VDC during motor regeneration, was not performed.
- 4) These devices should be mounted and used according to the manufacturer's directions and specifications with regard to compatibility with drive type (see Ratings Section) and braking resistor specification.
- 5) The manufacturer should provide in the end product all literature designating use of the devices as described in Condition of Acceptability 4) above.
- 6) Temperature testing was performed in a 150% outer enclosure and results found acceptable for use in 25°C ambient outside of the 150% outer enclosure. Use at elevated ambients with other enclosure configurations will require heat testing with the actual intended enclosure and the elevated ambient.

**DBU Wiring Terminal Specifications**

<b>BRAKING UNIT WIRING TERMINAL SPECIFICATIONS</b>					
<b>BRAKING UNIT MODELS: GS-1DBU, GS-2DBU, GS-3DBU, GS-4DBU</b>					
<b>CIRCUIT</b>	<b>TERMINAL MARK</b>		<b>WIRE SIZE</b>	<b>SCREW</b>	<b>TORQUE</b>
Power Input Circuit	+(P), -(N)		10–12 AWG [3.5–5.5 mm <sup>2</sup> ]	M4	15.6 in·lb [18 kg·cm]
Braking Resistor	B1, B2		10–12 AWG [3.5–5.5 mm <sup>2</sup> ]	M4	15.6 in·lb [18 kg·cm]
Slave Circuit	Output	M1, M2	18–20 AWG [0.8–0.5 mm <sup>2</sup> ] (with shielded wires)	M2	3 in·lb [4 kg·cm]
	Input	S1, S2			
Fault Circuit	RA, RB, RC		18–20 AWG [0.8–0.5 mm <sup>2</sup> ]	M2	3 in·lb [4 kg·cm]
<b>BRAKING UNIT MODELS: GS-5DBU, GS-6DBU, GS-7DBU</b>					
<b>CIRCUIT</b>	<b>TERMINAL MARK</b>		<b>WIRE SIZE</b>	<b>SCREW</b>	<b>TORQUE</b>
Power Input Circuit	DC+, DC-		4–6 AWG [21.2–13.3 mm <sup>2</sup> ]	M8	26 in·lb [30 kg·cm]
Braking Resistor	B1, B2		4–6 AWG [21.2–13.3 mm <sup>2</sup> ]	M8	26 in·lb [30 kg·cm]
Slave Circuit	Output	M1, M2	18–20 AWG [0.8–0.5 mm <sup>2</sup> ] (with shielded wires)	M2	3 in·lb [4 kg·cm]
	Input	S1, S2			
Fault Circuit	RA, RC		18–20 AWG [0.8–0.5 mm <sup>2</sup> ]	M2	3 in·lb [4 kg·cm]



**BASIC BRAKING WIRING DIAGRAM**

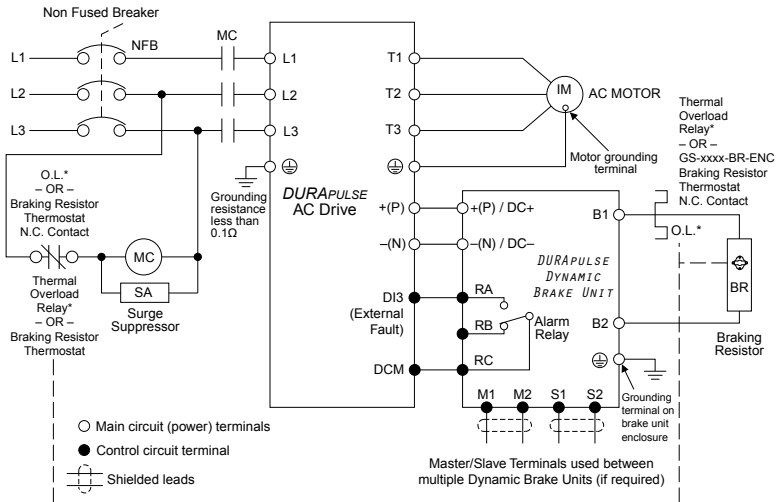

\* Although it is recommended, the use of a thermal overload relay in line with the braking resistor is not required. GS-xxxx-BR-ENC braking resistors include a thermostat for thermal protection of the braking resistor, and are the preferred method of protection when available. Orient the braking resistors such that the thermostat is above the resistors in the enclosure, as this will ensure that the thermostat is exposed to the rising air temperature produced by the resistors.



*Smaller-capacity DURApulse AC Drives can connect directly to braking resistors, and do not require Dynamic Braking Units for braking. Refer to the “Dynamic Braking Component Selection” section of Chapter 1 to determine which braking components are required for each drive.*



*Although it is recommended, the use of a thermal overload relay in line with the braking resistor is not required. GS-xxxx-BR-ENC braking resistors include a thermostat for thermal protection of the braking resistor, and are the preferred method of protection when available. Orient the braking resistors such that the thermostat is above the resistors in the enclosure, as this will ensure that the thermostat is exposed to the rising air temperature produced by the resistors.*



*For overload relay information, Refer to the “Overload Relay” section at the beginning of this chapter.*

**SPECIFIC BRAKING WIRING DIAGRAMS**
**Wiring Diagram Index for GS3 Drives**

GS3 AC DRIVE BRAKING WIRING DIAGRAM INDEX															
230VAC DRIVE AND MOTOR VOLTAGE						460VAC DRIVE AND MOTOR VOLTAGE									
MOTOR POWER		AC DRIVE	BRAKING UNIT		BRAKING RESISTOR		WIRING DIAGRAM	MOTOR POWER		AC DRIVE	BRAKING UNIT		BRAKING RESISTOR		WIRING DIAGRAM
(HP)	(KW)	PART #	QUANTITY	PART #	QUANTITY	PART #		(HP)	(KW)	PART #	QUANTITY	PART #	QUANTITY	PART #	
		GS3-	GS-	GS-	GS-	GS-				GS3-	GS-	GS-	GS-	GS-	
1	0.7	21P0	0	n/a	1	21P0-BR	A	1	0.7	41P0	0	n/a	1	41P0-BR	A
2	1.5	22P0			1	22P0-BR		2	1.5	42P0			1	42P0-BR	
3	2.2	23P0			1	23P0-BR		3	2.2	43P0			1	43P0-BR	
5	3.7	25P0			1	25P0-BR		5	3.7	45P0			1	45P0-BR	
7.5	5.5	27P5			1	27P5-BR		7.5	5.5	47P5			1	47P5-BR	
10	7.5	2010			1	2010-BR-ENC		10	7.5	4010			1	4010-BR	
15	11	2015	1	2015-BR-ENC	15	11	4015	1	4015-BR-ENC						
20	15	2020	1	2DBU	1	2020-BR-ENC	D	20	15	4020	1	4DBU	1	4020-BR-ENC	D
25	18	2025	1	2DBU	1	2025-BR-ENC		25	18	4025	1	4DBU	1	4025-BR-ENC	
30	22	2030	1	2DBU	1	2030-BR-ENC		30	22	4030	1	4DBU	1	4030-BR-ENC	
40	30	2040	2	2DBU	2	2040-BR-ENC		40	30	4040	1	4DBU	1	4040-BR-ENC	
50	37	2050	2	2DBU	2	2050-BR-ENC		50	40	4050	1	4DBU	1	4050-BR-ENC	
								60	45	4060	1	4DBU	1	4060-BR-ENC	
							75	55	4075	2	4DBU	2	4075-BR-ENC	F	
							100	75	4100	2	4DBU	2	4100-BR-ENC		

**Wiring Diagram Index for GS4 Drives**

<b>GS4 AC DRIVE BRAKING WIRING DIAGRAM INDEX</b>																		
<b>230VAC DRIVE AND MOTOR VOLTAGE</b>							<b>460VAC DRIVE AND MOTOR VOLTAGE</b>											
<b>MOTOR POWER</b>		<b>AC DRIVE PART #</b>	<b>BRAKING UNIT</b>		<b>BRAKING RESISTOR</b>		<b>DIAGRAM #</b>	<b>MOTOR POWER</b>		<b>AC DRIVE PART #</b>	<b>BRAKING UNIT</b>		<b>BRAKING RESISTOR</b>		<b>DIAGRAM #</b>			
<b>(HP)</b>	<b>(kW)</b>		<b>QUANTITY</b>	<b>PART #</b>	<b>QUANTITY</b>	<b>PART #</b>		<b>(HP)</b>	<b>(kW)</b>		<b>QUANTITY</b>	<b>PART #</b>	<b>QUANTITY</b>	<b>PART #</b>		<b>QUANTITY</b>	<b>PART #</b>	
		<b>GS4-</b>		<b>GS-</b>		<b>GS-BR-</b>			<b>GS4-</b>		<b>GS-</b>		<b>GS-BR-</b>					
1	0.7	21P0	0	n/a	1	080W200	A	1	0.7	41P0	0	n/a	1	080W750	A			
2	1.5	22P0			1	200W091		2	1.5	42P0			1	200W360				
3	2.2	23P0			1	300W070		3	2.2	43P0			1	300W250				
5	3.7	25P0			1	400W040		5	3.7	45P0			1	400W150				
7.5	5.5	27P5			1	1K0W020		7.5	5.5	47P5			1	1K0W075				
10	7.5	2010			1	1K0W020		10	7.5	4010			1	1K0W075				
15	11	2015			1	1K5W013		15	11	4015			1	1K5W043				
20	15	2020			2	1K0W4P3		20	15	4020			2	1K0W016				
25	18	2025			2	1K0W4P3		25	18	4025			2	1K0W016				
30	22	2030			2	1K5W3P3		30	22	4030			2	1K5W013				
40	30	2040			2	1K0W5P1		40	30	4040			4	1K0W016				
50	37	2050			2	2DBU		4	1K2W3P9	G			1	4DBU		4	1K2W015	E
60	45	2060			2	2DBU		4	1K5W3P3				1	4DBU		4	1K5W013	
75	55	2075			3	2DBU		6	1K2W3P9	J			2	3DBU		8	1K0W5P1	H
100	75	2100	4	2DBU	8	1K2W3P9	2	4DBU	8		1K2W015							
							K	2	4DBU	8	1K5W013	I						
								1	5DBU	10	1K2W015		M					
								1	6DBU	12	1K5W012							
								1	6DBU	12	1K5W012							
								1	7DBU	14	1K5W012							
								2	5DBU	20	1K2W015							

**Wiring Diagram A: [Drive + 1 Resistor]**

For GS3 230VAC Drives					For GS3 460VAC Drives						
AC Drive Part #	Braking Unit		Braking Resistor		Diag.	AC Drive Part #	Braking Unit		Braking Resistor		Diag.
	#	Part #	#	Part #			#	Part #	#	Part #	
GS3-21P0	0	n/a	1	GS-21P0-BR	A	GS3-41P0	0	n/a	1	GS-41P0-BR	A
GS3-22P0			1	GS-22P0-BR		GS3-42P0			1	GS-42P0-BR	
GS3-23P0			1	GS-23P0-BR		GS3-43P0			1	GS-43P0-BR	
GS3-25P0			1	GS-25P0-BR		GS3-45P0			1	GS-45P0-BR	
GS3-27P5			1	GS-27P5-BR		GS3-47P5			1	GS-47P5-BR	
GS3-2010			1	GS-2010-BR-ENC		GS3-4010			1	GS-4010-BR	
GS3-2015			1	GS-2015-BR-ENC		GS3-4015			1	GS-4015-BR-ENC	

For GS4 230VAC Drives					For GS4 460VAC Drives						
AC Drive Part #	Braking Unit		Braking Resistor		Diag.	AC Drive Part #	Braking Unit		Braking Resistor		Diag.
	#	Part #	#	Part #			#	Part #	#	Part #	
GS4-21P0	0	n/a	1	GS-BR-080W200	A	GS4-41P0	0	n/a	1	GS-BR-080W750	A
GS4-22P0			1	GS-BR-200W091		GS4-42P0			1	GS-BR-200W360	
GS4-23P0			1	GS-BR-300W070		GS4-43P0			1	GS-BR-300W250	
GS4-25P0			1	GS-BR-400W040		GS4-45P0			1	GS-BR-400W150	
GS4-27P5			1	GS-BR-1K0W020		GS4-47P5			1	GS-BR-1K0W075	
GS4-2010			1	GS-BR-1K0W020		GS4-4010			1	GS-BR-1K0W075	
GS4-2015			1	GS-BR-1K5W013		GS4-4015			1	GS-BR-1K5W043	

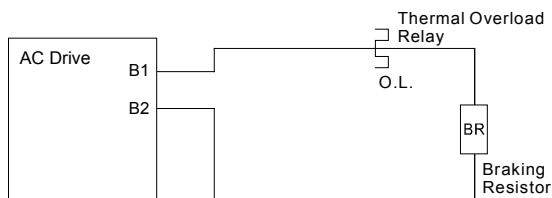

**Wiring Diagram B: [Drive + 2 Series Resistors]**

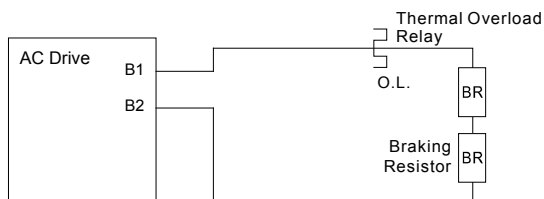
For GS4 230VAC Drives					For GS4 460VAC Drives						
AC Drive Part #	Braking Unit		Braking Resistor		Diag.	AC Drive Part #	Braking Unit		Braking Resistor		Diag.
	#	Part #	#	Part #			#	Part #	#	Part #	
GS4-2020	0	n/a	2	GS-BR-1K0W4P3	B	GS4-4020	0	n/a	2	GS-BR-1K0W016	B
GS4-2025			2	GS-BR-1K0W4P3		GS4-4025			2	GS-BR-1K0W016	
GS4-2030			2	GS-BR-1K5W3P3		GS4-4030			2	GS-BR-1K5W013	

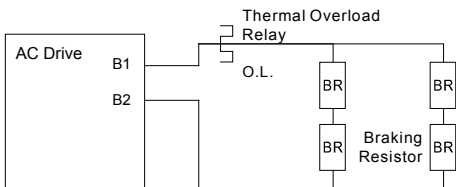

**Wiring Diagram C: [Drive + (2 Series + 2 Parallel) Resistors]**

For GS4 460VAC Drives					Diag.
AC Drive	Braking Unit		Braking Resistor		
Part #	#	Part #	#	Part #	
GS4-4040	0	n/a	4	GS-BR-1K0W016	C



**Wiring Diagram D: [Drive + 1 DBU + 1 Resistor]**

For GS3 230VAC Drives					Diag.	For GS3 460VAC Drives					Diag.
AC Drive	Braking Unit		Braking Resistor			AC Drive	Braking Unit		Braking Resistor		
Part #	#	Part #	#	Part #		Part #	#	Part #	#	Part #	
GS3-2020	1	GS-2DBU	1	GS-2020-BR-ENC	D	GS3-4020	1	GS-4DBU	1	GS-4020-BR-ENC	
GS3-2025	1	GS-2DBU	1	GS-2025-BR-ENC		GS3-4025	1	GS-4DBU	1	GS-4025-BR-ENC	
GS3-2030	1	GS-2DBU	1	GS-2030-BR-ENC		GS3-4030	1	GS-4DBU	1	GS-4030-BR-ENC	
n/a						GS3-4040	1	GS-4DBU	1	GS-4040-BR-ENC	
						GS3-4050	1	GS-4DBU	1	GS-4050-BR-ENC	
n/a					GS3-4060	1	GS-4DBU	1	GS-4060-BR-ENC		

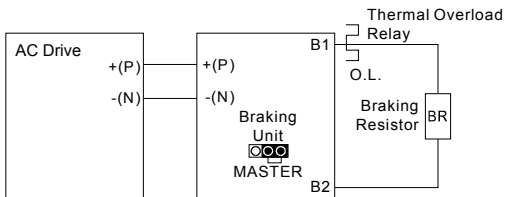

**Wiring Diagram E: [Drive + 1 DBU + (2 Series + 2 Parallel) Resistors]**

For GS4 460VAC Drives					Diag.
AC Drive Part #	Braking Unit #	Part #	Braking Resistor #	Part #	
GS4-4050	1	GS-4DBU	4	GS-BR-1K2W015	E
GS4-4060	1	GS-4DBU	4	GS-BR-1K5W013	

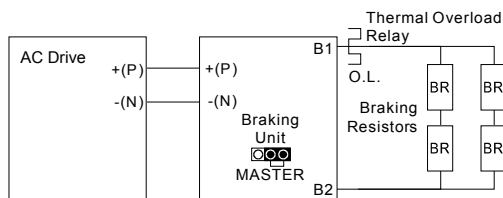
**Wiring Diagram F: [Drive + 2 DBUs + 1 Resistor/DBU]**

For GS3 230VAC Drives					Diag.	For GS3 460VAC Drives					Diag.
AC Drive Part #	Braking Unit #	Part #	Braking Resistor #	Part #		AC Drive Part #	Braking Unit #	Part #	Braking Resistor #	Part #	
GS3-2040	2	GS-2DBU	2	GS-2040-BR-ENC	F	GS3-4075	2	GS-4DBU	2	GS-4075-BR-ENC	F
GS3-2050	2	GS-2DBU	2	GS-2050-BR-ENC		GS3-4100	2	GS-4DBU	2	GS-4100-BR-ENC	

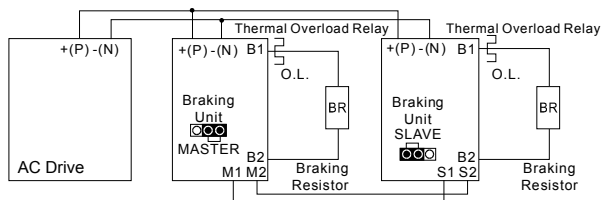

**Wiring Diagram G: [Drive + 2 DBUs + 2 Series Resistors/DBU]**

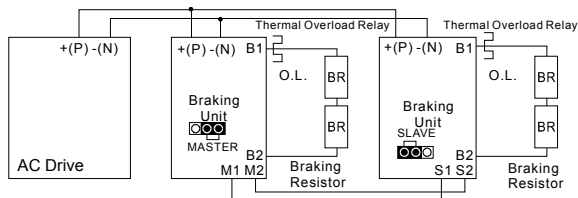
For GS4 230VAC Drives					Diag.
AC Drive Part #	Braking Unit #	Part #	Braking Resistor #	Part #	
GS4-2040	2	GS-1DBU	4	GS-BR-1K0W5P1	G
GS4-2050	2	GS-2DBU	4	GS-BR-1K2W3P9	
GS4-2060	2	GS-2DBU	4	GS-BR-1K5W3P3	

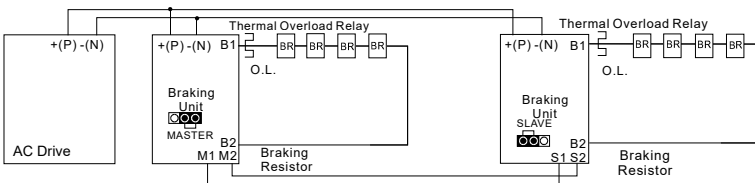

**H: [Drive + 2 DBUs + 4 Parallel Resistors/DBU]**

For GS4 460VAC Drives					
AC Drive	Braking Unit		Braking Resistor		Diag.
Part #	#	Part #	#	Part #	
GS4-4075	2	GS-3DBU	8	GS-BR-1K0W5P1	H



**Wiring Diagram I: [Drive + 2 DBUs + (2 Series + 2 Parallel) Resistors/DBU]**

For GS4 460VAC Drives					
AC Drive	Braking Unit		Braking Resistor		Diag.
Part #	#	Part #	#	Part #	
GS4-4100	2	GS-4DBU	8	GS-BR-1K2W015	I
GS4-4125	2	GS-4DBU	8	GS-BR-1K5W013	

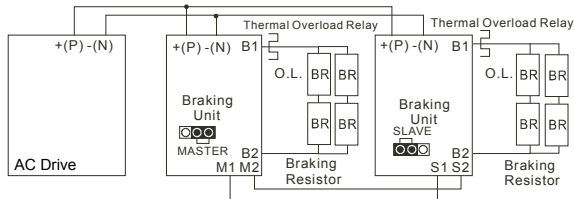

**Wiring Diagram J: [Drive + 3 DBUs + 2 Series Resistors/DBU]**

For GS4 230VAC Drives					
AC Drive	Braking Unit		Braking Resistor		Diag.
Part #	#	Part #	#	Part #	
GS4-2075	3	GS-2DBU	6	GS-BR-1K2W3P9	J

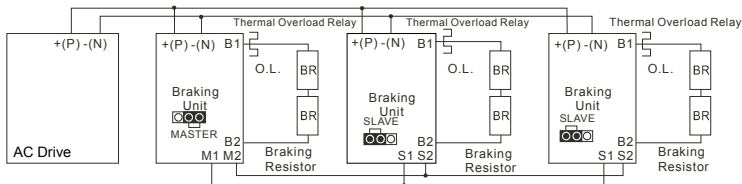

**Wiring Diagram K: [Drive + 4 DBUs + 2 Series Resistors/DBU]**

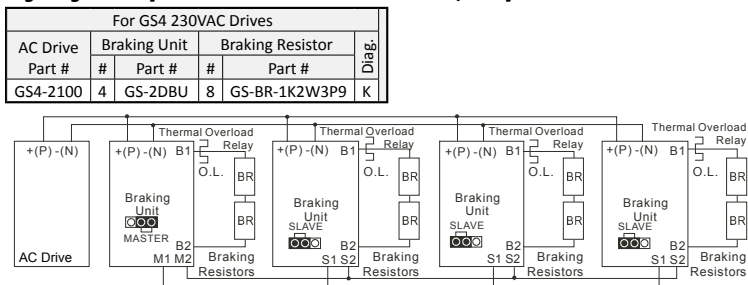

**Wiring Diagram L: [Drive + 1 DBU + (2 Series + 5 Parallel) Resistors/DBU]**

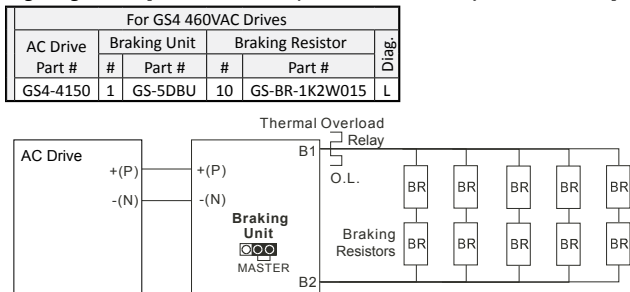

**Wiring Diagram M: [Drive + 1 DBU + (2 Series + 6 Parallel) Resistors/DBU]**

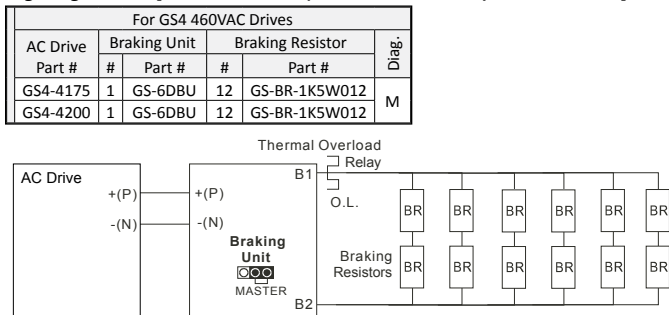



**Wiring Diagram N: [Drive + 1 DBU + (2 Series + 7 Parallel) Resistors/DBU]**

For GS4 460VAC Drives					
AC Drive	Braking Unit		Braking Resistor		Diag.
Part #	#	Part #	#	Part #	
GS4-4250	1	GS-7DBU	14	GS-BR-1K5W012	N

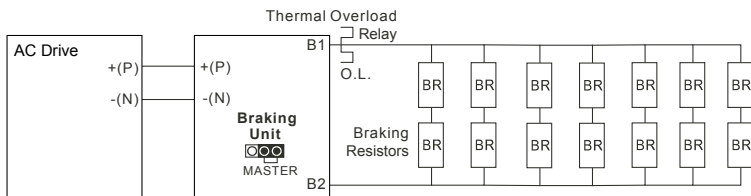

**Wiring Diagram O: [Drive + 2 DBUs + (2 Series + 5 Parallel) Resistors/DBU]**

For GS4 460VAC Drives					
AC Drive	Braking Unit		Braking Resistor		Diag.
Part #	#	Part #	#	Part #	
GS4-4300	2	GS-5DBU	20	GS-BR-1K2W015	O

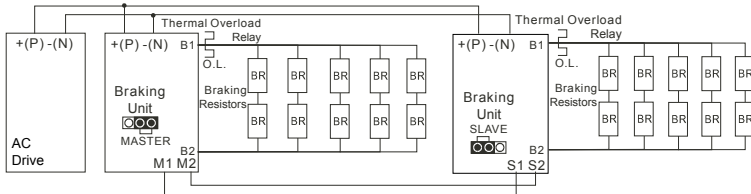

BLANK  
PAGE