

Moving towards tomorrow

Rotary Encoder

High performance and precise control

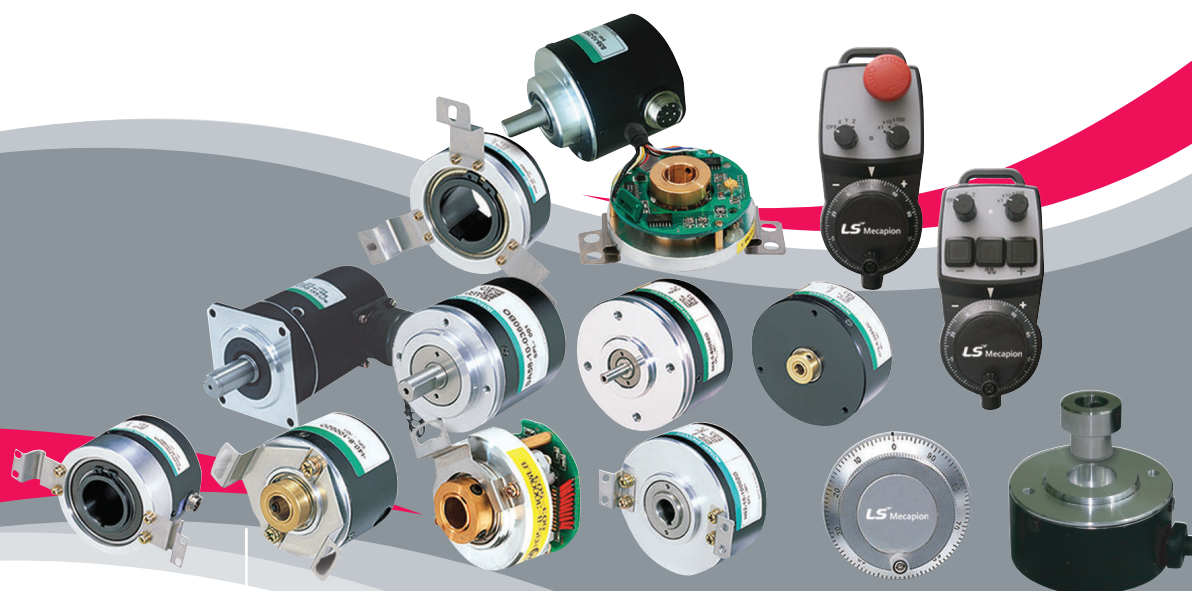

LS Mecapion
Products Collection Vol. 2.0

Rotary Encoder

High performance and precise control

Various type with high resolution

- Shaft type : $\Phi 30 \sim \Phi 78$
- Hollow shaft type : $\Phi 30 \sim \Phi 128$
- MPG : Panel attach type, Portable type
- Incremental type, Absolute type, Magent type
- Customized models
- Various output type
- Resolution : 10P/R \sim 6,000P/R

High stability

- Strong against noise with digital output
- Various power input
- High compatibility with various machine
- Easy to apply

Application

- Elevator
- Lubrication
- FA Machine
- Industrial Motor

Contents

10	S30B Series (200 \sim 1024 P/R)	30	H88B Series (512, 1024 P/R)
12	S40 Series (10 \sim 3600 P/R)	32	H88-30C Series (512, 1024 P/R)
14	S48 Series (10 \sim 6000 P/R)	34	H100 Series (512, 1024 P/R)
16	S68A Series (100 \sim 2048 P/R)	36	SM60 Series
18	S78 Series (512 P/R)	38	SM80 Series (100 P/R)
20	H40 Series (10 \sim 3600 P/R)	40	SPM Series (100 P/R)
22	H42 Series (2000 \sim 6000 P/R)		
24	H45A Series (2000 \sim 6000 P/R)		
26	H60 Series (2000 \sim 6000 P/R)		
28	H62 Series (1000 \sim 2048 P/R)		



>>> The definition of Rotary Encoder

Encoder is light sensor that detects and converts mechanical transfer or displacement into electric signal. It detects the position, speed, angle of FA System by means of converting analog signal generated from a revolution of the shaft into digital signal by the internal fixed circuit.

>>> The characteristics of Rotary Encoder

- High Resolution
 - We can provide the high resolution encoder because we make high-precision board of signs through Photo Etching method.
- Easy to record the measuring value
 - The digital output makes it easy to measure the value, and prevent error caused by operator's carelessness.
- High Stability
 - Since it can make a digital output, it is not influenced by noise even if there is some time-delay.
- Various kinds of type
 - There are various kinds of rotary encoder with wide resolution, appearance. So the price is very cheap and any kind of type can be obtained as per the customer's request.

>>> The Composition of Rotary Encoder

- Rotary Encoder is basically composed of equipment part, light-absorbing / light emitting part, circuit part but it may be different depending on the model.
- The equipment part is composed of shaft, shaft, frame and bearing. The light-absorbing / light emitting part are composed of light-absorbing element, light emitting element and disk/mask. The circuit part is composed of the circuit which formalizes the signal generated from light-absorbing element.

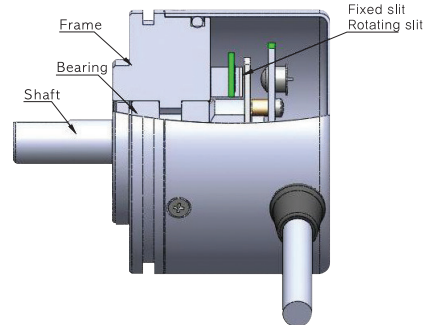

>>> The principle of Rotary Encoder

INCREMENTAL ENCODER

- The light generated from light emitting element passes through rotating and fixed slit. The light energy is converted into current through light-absorbing element and passes through fixed-waved circuit & output circuit and output as two spherical pulses which have different phase of 1/4 cycle.
 - It is output as spherical wave depending on the amount of rotating displacement of the shaft.
 - The external counter figures out the number of pulses and the amount of rotating displacement is detected.
 - You have to set the origin to find a certain rotating displacement and add the number of pulse from the origin accumulatively.
 - You can add the extra circuit to the output circuit of encoder and improve the electric resolution by increasing the output pulse 2times, 4times.
 - You have to find the origin newly when the power is re-provided after power failure.

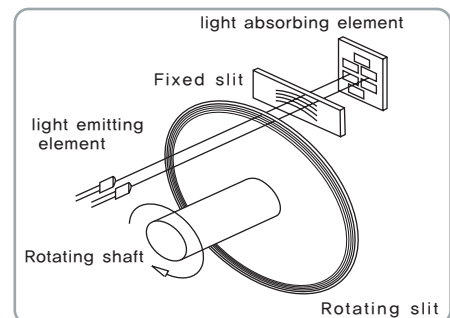

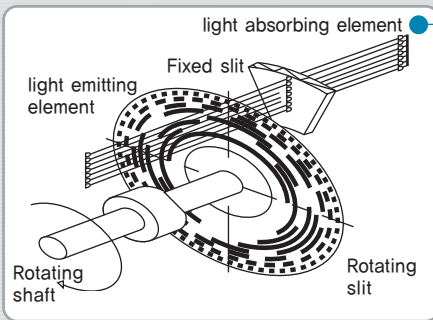

Absolute Encoder

- The basic principle of absolute encoder is same as incremental encoder. Incremental encoders output as two different square-wave pulses, while absolute encoders output as digital code (Binary, BCD, Gray code).
 - The amount of rotating displacement is output as parallel 2^n . More the number of output code's bit is, higher the resolution is.
 - It detects the rotating position by reading the output code directly.
 - Once the origin of input rotating shaft is fixed, the rotating angle whose coordinates origin is always in the origin is output as digital code.
 - It always maintains the absolute position when the power is re-provided after power failure.

The output circuit type of Rotary Encoder

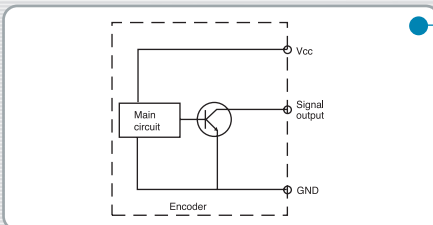

Open Collector

- The emitter terminal of transistor is connected to 0[V] by using NPN transistor in output side of encoder and open the collector terminal with + Vcc and use it for output terminal. It is recommended when encoder and collector does not coincide on the power voltage.

⟨Application⟩ FA for general use, Textile machine, Lubricator, Automation Machine, Injection machine, Cutting machine, Printing machine, Packaging machine

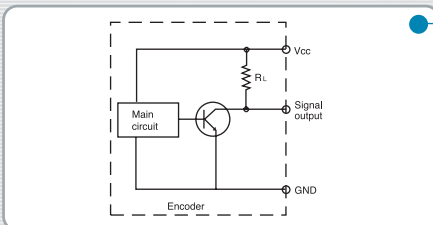

Voltage Output

- The emitter terminal of transistor is connected to 0[V] by using NPN transistor in output side of encoder and the collector terminal is connected with + Vcc and load resistor and use it for output terminal.

It is recommended when the voltage of the applicable equipment is same as the voltage of encoder and no-load is applied to the input side of used machine.

⟨Application⟩ FA for general use, Textile machine, Lubricator, Automation Machine, Injection machine, Cutting machine, Printing machine, Packaging machine.

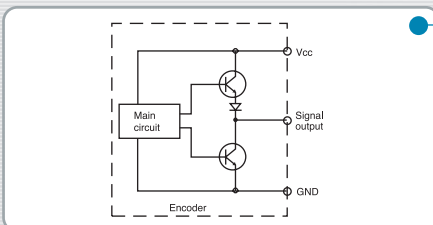

Totem Pole

- Totem pole is composed of two NPN transistor between +Vcc of encoder output circuit and 0[V], which is complement output type. If one transistor is ON, another should be OFF. The current inflows at both directions through two transistors of output side and output current flows all the time. So it has low impedance and is not much influenced by noise and deformed wave. It can be also used for voltage output and open collector type.

⟨Application⟩ FA for general use, Textile machine, Lubricator, Automation Machine, Injection machine, Cutting machine, Printing machine, Packaging machine.

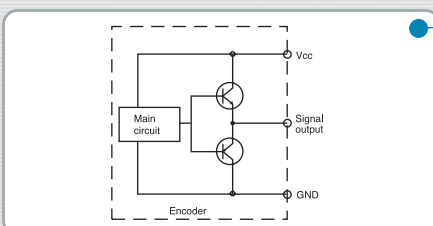

Complemental or Push-Pull Output

- It is composed of the upper PNP type transistor and the lower NPN type transistor. It is also complement output type just like Totem pole; If one transistor is ON, another should be OFF. It has high input impedance and low output impedance so it is possible to provide large-scale power even under low impedance and is suitable for long-distance transmission because it has same phase of input/output signal and wide frequency area.

⟨Application⟩ Elevator (special customized)

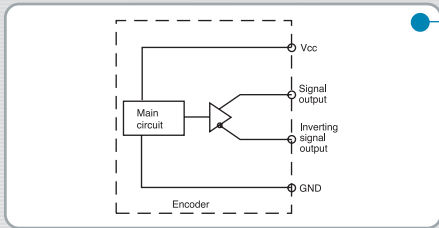

Line Driver

- It applies the exclusive IC(26LS31) for Line driver to the encoder output circuit. The exclusive IC for Line driver is suitable for long-distance transmission because it has high-speed response and good noise-proof. For the receiver of controller which receives the line driver output of encoder, IC(26LS32) which is corresponding to RS-422A should be used.
(Application) AC Servo system, DC Servo System, Robot, A.G.V., NC Construction machine

The example of output connection for Rotary Encoder

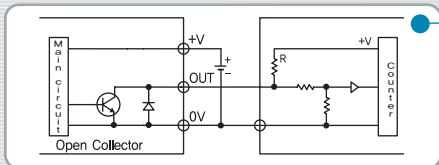

The output connection with counter

- In case that open collector type of encoder is connected to the counter, you have to connect Pull up resistor to the receiving circuit and the resistor[R] should be set less than 1/5 of input impedance.

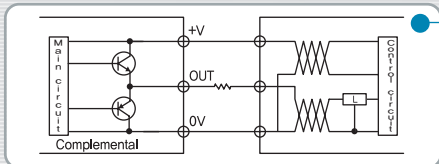

The output connection of Complementary type

- In case of complementary output type, the current inflows all the time since two transistors complements each other. It is suitable for middle-distance transmission since it has good noise-proof and low distorted wave, which is mainly applied for elevator.

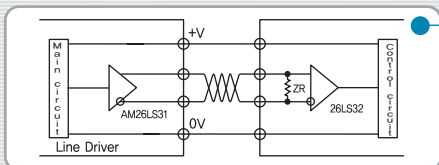

The output connection of Line Driver type

- In case of Line driver output type, For the receiving circuit which receives the output of encoder, you have to use IC(26LS32) which is corresponding to RS422A. You have to also apply use Twist pair cable .

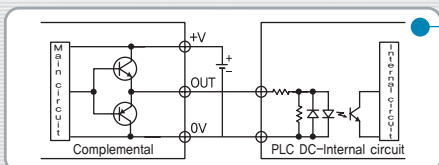

The output connection of Encoder and PLC

- In case that you connect the encoder to the PLC, you can use them by connecting directly DC input unit of encoder and PLC. In this case, the input scanning frequency of DC input unit of PLC which receive the output of encoder should be higher than max. response frequency of encoder.(Approximately, more than 10 times)
In case that the power is not stable when you apply the DC power of PLC to the encoder, the encoder may have malfunction so you have to use separately the stable DC power for encoder.

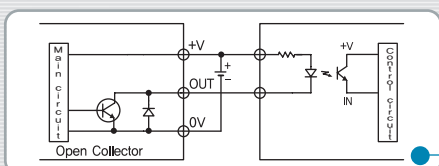

The output connection with Photo coupler

- In case of connecting rotary encoder and photo coupler, the resistor[R] should not exceed the operating current of photo coupler and encoder's max. load current. The response of photo coupler should be faster than max. response frequency of encoder to secure the allowance of response.

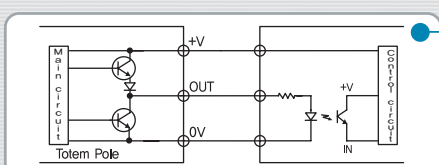
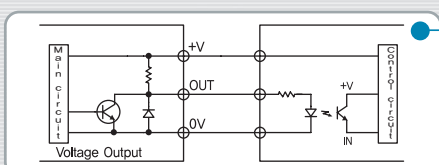

Notice for applying Rotary Encoder

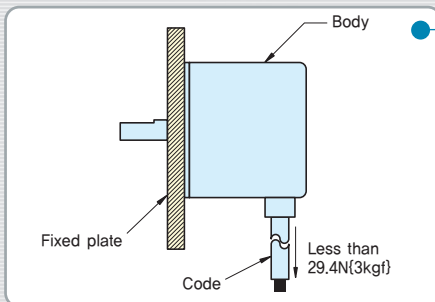
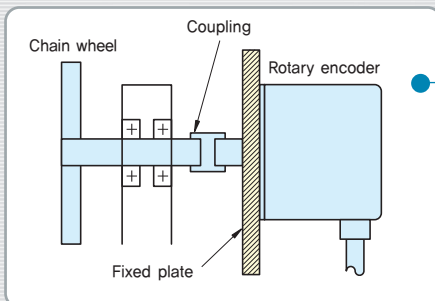
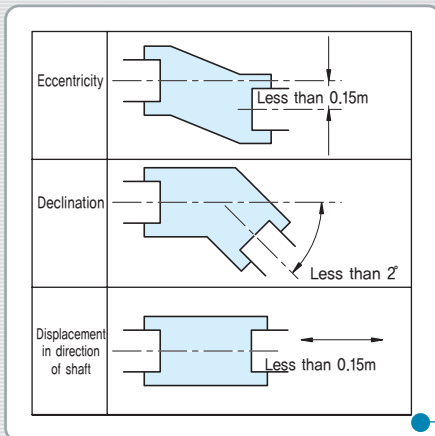

■ Circumstances

- Do not use rotary encoder in the below circumstances.
 - The place where the equipment may be defected due to the excessive vibration and impact.
 - Nearby the equipment which emits strong magnetism and electric noise.
 - The place which has inflammable or corrosive gas, liquids or dust.
 - The place where the temperature and humidity exceeds the propriety
 - Nearby the strong alkali / acid materials.
 - The place exposed to direct sunlight.

■ Instructions to install encode

- Please don't splash water or oil to the body.
- As rotary encoder is composed of precision components, you must handle it with care.
- In case of forward, reverse rotation, you have to check the installation direction and adjusting direction.
- In case that you set the origin of the applicable equipment at Z phase of encoder, please make sure to check the position of Z phase.
- In case of gear connection, mind that you do not inflict the excessive load to the rotating shaft.
- In case of fixing with screw, please tighten with less than 0.49N.m[5kg .f.]
- In case of using coupling, make sure to install it within permitted limit.
- Please be noted that if installation error(partial disposition, declination) encoder may be broken or the life span may be shortened.
- In case of connecting with chain timing belt or wheel, the extra bearing and coupling will be needed to connect encoder.

■ Instructions for wiring

- For Rotary encoder, please provide the power independently within the rated voltage.
- In case that you wire the coder after fixing the product, the power to pull the code should not exceed 29.4N[3kgf].
- Please check the connection to avoid the mis-wiring. In case of short, the product may be broken or damaged.
- Wiring work should be done after cutting off the power. In case that the power is on, the output circuit may be damaged.
- In case of wiring high-tension wire and power line at the same time, the malfunction caused by induction noise or damage may occur. So please use the separate wiring.
- In case that serge occurs at the used power, please suck serge by connecting serge observer between power.
- In case of no used output line, FG line, they should be insulated.

■ Instructions in case of extending wiring

- Please make sure that you have to use Twist Pair Shield cable when you extend the rotary encoder cable.
 - Line Driver → Vcc-0V, A-A, B-B, Z-Z
 - Open Collector, Voltage Output, Totem Pole, Complemental → Vcc-0V, A-0V, B-0V, Z-0V

- In case of extending the wiring, remaining voltage of output signal may be increased or the wave may be distorted due to phase to phase resistance or phase to phase capacity.
- The wiring work should be shortest to avoid induction noise.
- In case of extending the wiring, opening time of output wave will be extended and it may influence the phase difference of A, B phase.
- In case of extending the wiring, Line Driver output type is recommended. Please provide DC 5[V] of the power supply for Line Drive and be noted that the voltage drops by approximately 1[V] when you make it 100m longer.

■ Instructions under vibration

- When you apply vibration to the rotary encoder, wrong pulse will occur and it leads to malfunction so you must handle it with care.
- Please make sure that you do not transmit the vibration generated from rotation or stop to the encoder since higher encoder's resolution is, more wrong pulse is due to vibration.

■ Noise-control Measures

- You are requested to provide the power independently.
- If case that the transmitting distance is long, please insert a number of μF Condenser which is for noise filter between case ground circuit and ground.
- Keep away from the source of noise, and shorten the wiring work for encoder.

The procedures to select the rotary encoder

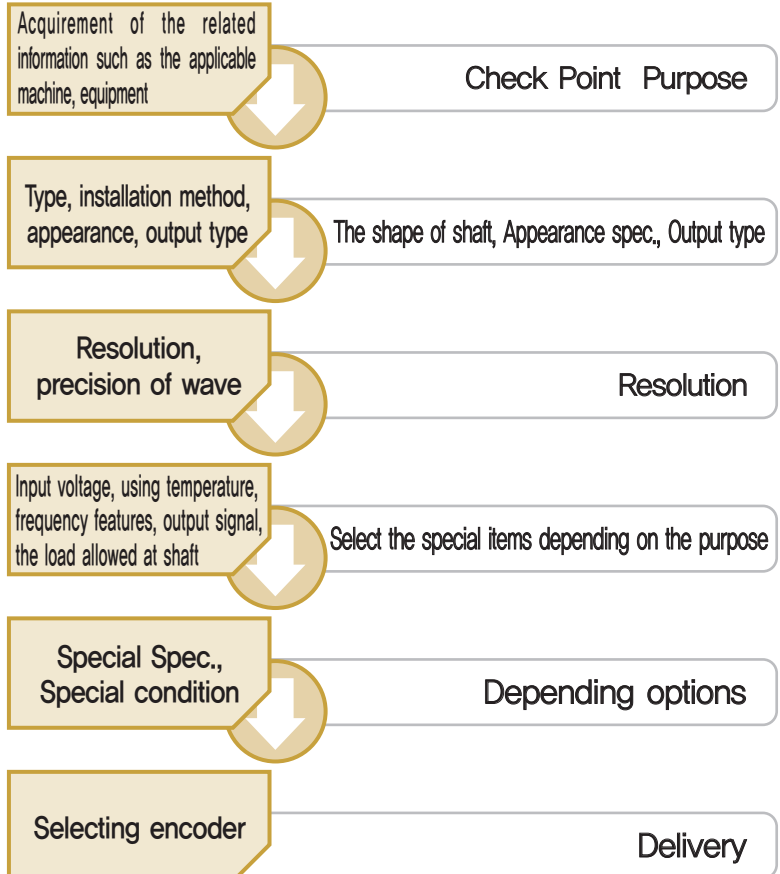

Terms

■ Resolution[P/R]

- It means the number of pulse which is output from 1 revolution of the rotating shaft of rotary encoder. In case of Incremental encoder, it can be indicated in the number of rotating slits, in case of Absolute encoder, it can be indicated in number of division or bit.

■ Power voltage (Symbol : [Vcc], Unit : [V])

- It means the voltage which is applied to the rotary encoder. Please make sure to check the power voltage of the related product and input the voltage within the limits of rated voltage.

■ Consuming current(Symbol ; [Icc], Unit : [m A])

- It means the current which encoder consumes when the power is applied to the encoder. Please make sure to use it within rated consuming current.

■ Moving Torque (Symbol : [Tr], Unit : [g-cm])

- It means the minimum power to rotate the rotation shaft when rotary encoder stops. Generally, the torque is less than the moving torque.

■ The max. response frequency (Symbol : [fr], Unit : [kHz])

- It means the max output pulse which rotary encoder can response per 1 second.
- Max. response frequency = Max. rpm/60 x resolution.
- Please make sure to use it within max. allowable rpm and determine the resolution within rated max. rpm.

■ Max. allowable rpm. (Symbol ; [Nr], Unit : [rpm])

- It means the max. rpm which rotary encoder allows mechanically and it may affect the lifespan of encoder. Please make sure to use it within rated limits.

■ Allowable shaft load (Unit : [kgf])

- It indicates the allowed radial and axial load when the shaft is rotated.

■ Position deflection of allowable shaft (Unit : [mm])

- It indicates the position deflection when coupling or shaft is connected to the shaft of rotary encoder.

■ Bearing lifespan (Symbol : [hs], Unit : [hrs])

- The bearing lifespan of rotary encoder is in inverse proportion to the load of rpm. In case that input rpm and shaft load are lower, it depends on the lifespan of grease.

■ Forward rotation (Symbol : [CW])

- It means CW rotation in direction of rotating shaft. In case of Incremental encoder, A phase is output before B phase and absolute encoder indicates the direction to increase code.

■ A, B Phase

- The output signal of A, B phase are output with 90° of phase difference. It is the signal to discriminate the rotation direction.

■ Z phase

- One Z phase is output per one rotation, which is called origin signal.

■ Isolation Resistor (Unit : [MΩ])

- It means the resistance between whole terminal of electric circuit and Case Ground

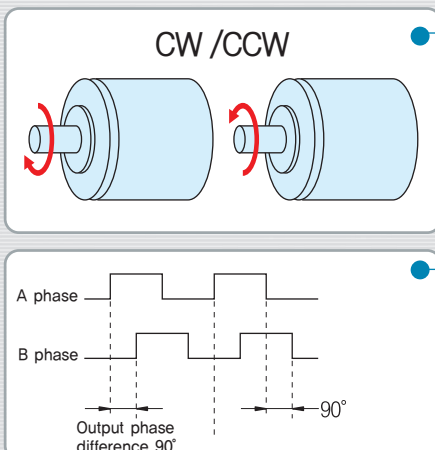

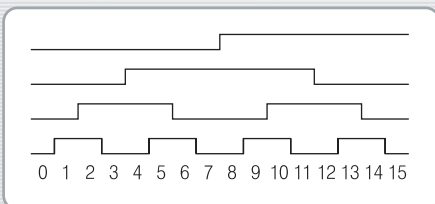
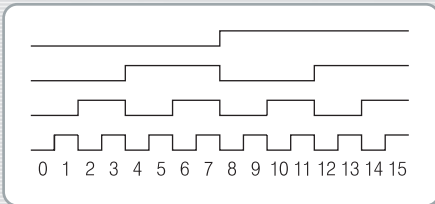
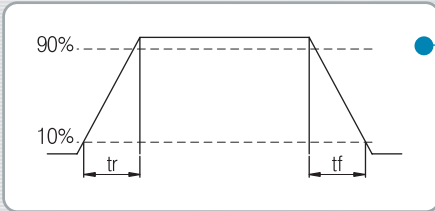

■ Vibration-proof (Unit : [G])

- It means the ability that rotary encoder is proof against the vibration, which is based on the vibration test.

■ Impact-Proof (Unit : [G])

- It indicates the ability that rotary encoder is proof against the impact when it falls twice from a height of 1m in direction of X, Y, Z axis.

■ Rising(tr) / Decline(tf) Time

- Rising time : The time to reach the initial 10%~90% (When signal level is 100%)
- Decline time : The time to reach 90%~100% (When signal level is 100%)

■ Using temperature (Unit : [°C])

- It means the range of surrounding temperature to meet the performance of rotary encoder.

■ Maintaining Temperature (Unit : [°C])

- It means the range of temperature not to flame the performance of rotary encoder.(suspension of power supply)

■ Bias Condenser

- It means the condenser which is connected between 0[V] of electric circuit of rotary encoder and encoder frame.

■ Binary Encoder

- It is one of output coder of Absolute encoder, which is the basic code to process digital signal. However, both 0 and 1 may be changed at the same time and the data may be mis-read due to time error.

Decimal	0	1	2	3	4	5	6	7	8	9	10	11	12	13	14	15
2 ³	0	0	0	0	0	0	0	0	1	1	1	1	1	1	1	1
2 ²	0	0	0	0	1	1	1	1	0	0	0	0	1	1	1	1
2 ¹	0	0	1	1	0	0	1	1	0	0	1	1	0	0	1	1
2 ⁰	0	1	0	1	0	1	0	1	0	1	0	1	0	1	0	1

■ Gray Code

- It can avoid the same error as the binary coder to complement the weak point of it.
In case of changing the number, either 0 or 1 may be changed.

Decimal	0	1	2	3	4	5	6	7	8	9	10	11	12	13	14	15
2 ³	0	0	0	0	0	0	0	0	1	1	1	1	1	1	1	1
2 ²	0	0	0	0	1	1	1	1	1	1	1	1	0	0	0	0
2 ¹	0	0	1	1	1	1	0	0	0	0	1	1	1	1	0	0
2 ⁰	0	1	1	0	0	1	1	0	0	1	1	0	0	1	1	0

■ BCD Code

- It is one of output coder of Absolute encoder, which indicates the number (up to 10) as the binary system. It can be usually used for controller of system and counter.

Decimal	0	1	2	3	4	5	6	7	8	9	10	11	12	13	14	15
2 ³ ×10 ⁰	0	0	0	0	0	0	0	0	1	1	0	0	0	0	0	0
2 ² ×10 ⁰	0	0	0	0	1	1	1	1	0	0	0	0	0	0	1	1
2 ¹ ×10 ⁰	0	0	1	1	0	0	1	1	0	0	0	0	1	1	0	0
2 ⁰ ×10 ⁰	0	1	0	1	0	1	0	1	0	1	0	1	0	1	0	1

INCREMENTAL SHAFT TYPE S40 Series

- Features : Various resolution, 10~3600 P/R(21 Class)
- Wide ranging power voltage, Customized design,
- Prompt delivery



Model

INCREMENTAL
SHAFT TYPE
Outer Diameter $\varnothing 40$

Shaft Size

6 : $\varnothing 6$ ※Option : 5 : $\varnothing 5$

S40 - 6 -



Resolution(P/R)

- 0010 0030 0048 0050 0100
- 0125 0200 0250 0256 0300
- 0360 0500 0512 0600 1000
- 1024 2000 2048 2500 3000
- 3600

Output Signal

- B : A, B
- Z : A, B, Z
- U : A, \bar{A} , B, \bar{B}
- V : A, \bar{A} , B, \bar{B} , Z, \bar{Z}

Output Form

- O : Open Collector
- V : Voltage Output
- C : Complemental
- T : Totem Pole
- L : Line Driver

Cable Length

- 1 : 1[M]
- 2 : 3[M]
- 3 : 5[M]
- 4 : 10[M]



The spec. of power may be different depending on the type of output and be sure to check the electric spec.

External Dimension

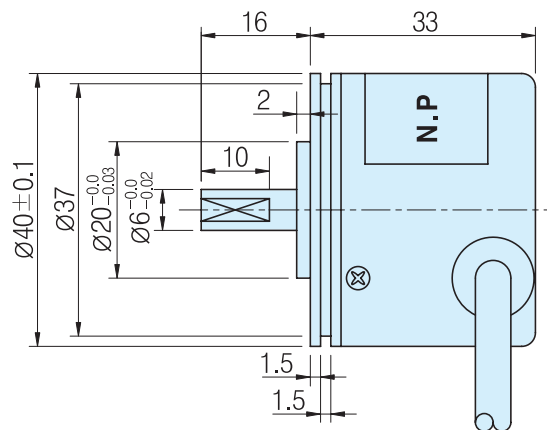
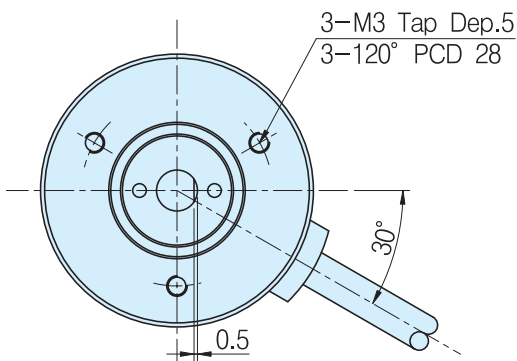

Output Circuit

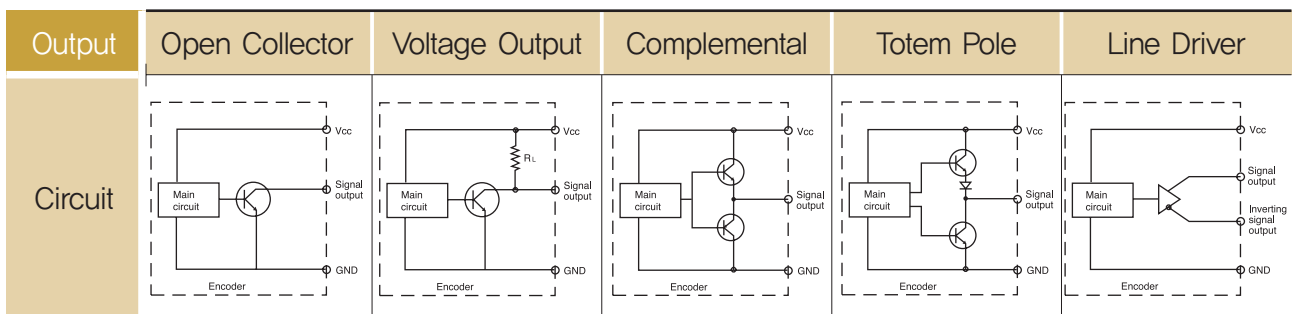

Electrical Spec.

Output type	Open Collector	Voltage Output	Complemental	Totem Pole	Line Driver
Power Supply	DC +5[V] ~ +24[V] Ripple p-p : less than 5%	DC +5[V] ~ +24[V] Ripple p-p : less than 5%	DC +15[V], +24[V] Ripple p-p : less than 5%	DC +5[V] ~ 24[V] Ripple p-p : less than 5%	DC +5[V] Ripple p-p : less than 5%
Consuming Current (In case of no load)	70mA Max	70mA Max	150mA Max	150mA Max	150mA Max
Maximum Response Frequency	150 KHz (10 ~ 2048 P/R) / 300 KHz (2500 ~ 3600 P/R)				
Output voltage	Less than $V_i \cdot 0.5[V]$ / More than $V_i \cdot 2.5[V]$ (In case of inputting +5V), / More than $V_i \cdot 10[V]$ (In case of inputting +15V) / More than $V_i \cdot 18[V]$ (In case of inputting +24V)				
Output current	Less than 20mA	Less than 20mA	Less than 10mA	Less than 10mA	Less than 20mA
Rising, decline time	Less than 3 μ s	Less than 3 μ s	Less than 1 μ s	Less than 1 μ s	Less than 0,1 μ s
Common conditions	In case that the cable length of output side is 1[M] and load resistance is less than 1[k Ω]				

Mechanical Spec.

Starting Torque	50gf – cm Max
Maximum number of revolution	7000 rpm
Bearing lifetime	20,000[hr](In case of rotating by 5000rpm)
Allowable Shaft Load	Radial : 2,2kg Max Axial : 1,1kg Max
Position deflection of allowable shaft	Radial : Less than 0,05 mm Axial : Less than 0,2mm
Connection Table	4P(AWG26) Shield CABLE
weight	150g

Rigid Spec.

Operating Temp. Range	-10°C ~ +70°C (No freezing)
Preserving temp	-20°C ~ +85°C
Using humidity	35% ~ 85% RH
Preserving Humidity	30% ~ 90% RH
Internal Vibration	5G
Internal Shock	50G
Degree of Protection	IP 50

Output Phase Shift

CW \Rightarrow Clockwise viewed from shaft end
 $a + b, c + d = T/2 \pm T/10$
 $a, b, c, d = T/4 \pm T/10$



**Open Collector, Voltage Output
Complemental, Totem Pole**

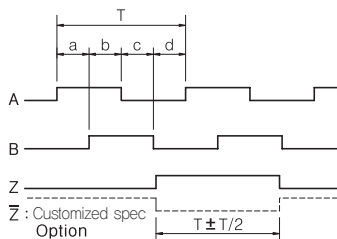

Line Driver

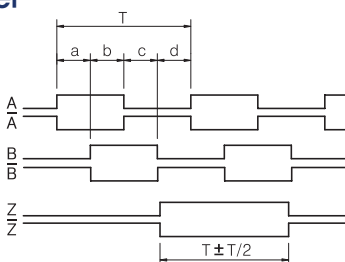

Connection Table

Cable's Color	Connection Table	
	Output Form	Line Driver
	Open Collector Voltage Output Complemental Totem Pole	
Red	Vcc	Vcc
Black	GND	GND
Green	A Sig	A Sig
Blue	-	\bar{A} Sig
White	B Sig	B Sig
Pink	-	\bar{B} Sig
Yellow	Z Sig	Z Sig
Orange	-	\bar{Z} Sig
Shield	CASE Shield	CASE Shield

INCREMENTAL SHAFT TYPE S48 Series

- Features : Various resolution, 10~6000 P/R(23 class)
Wide ranging power voltage, Customized design,
Prompt delivery



Model

INCREMENTAL
SHAFT TYPE
Outer Diameter $\varnothing 48$

Shaft Size

8 : $\varnothing 8$ ※Option : 6 : $\varnothing 6$

S48 - 8 -



Resolution(P/R)

- 0010 0030 0048 0050 0100
- 0125 0200 0250 0256 0300
- 0360 0500 0512 0600 1000
- 1024 2000 2048 2500 3000
- 3600 5000 6000

Output Signal

- B : A, B
- Z : A, B, Z
- U : A, \bar{A} , B, \bar{B}
- V : A, \bar{A} , B, \bar{B} , Z, \bar{Z}

Output Form

- O : Open Collector
- V : Voltage Output
- C : Complemental
- T : Totem Pole
- L : Line Driver

Cable Length

- 1 : 1[M]
- 2 : 3[M]
- 3 : 5[M]
- 4 : 10[M]



The spec. of power may be different depending on the type of output and be sure to check the electric spec.

External Dimension

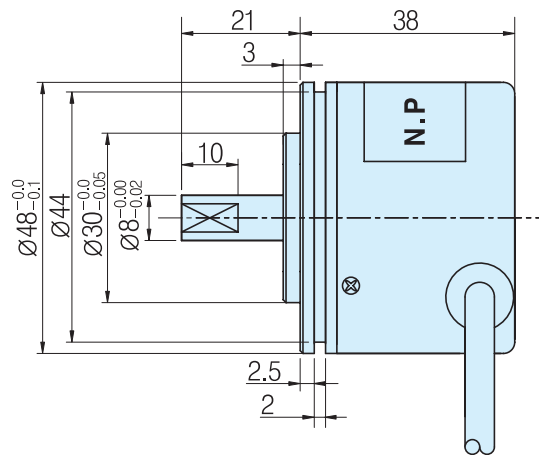
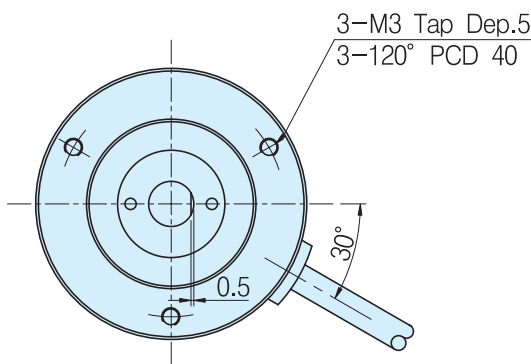

Output Circuit

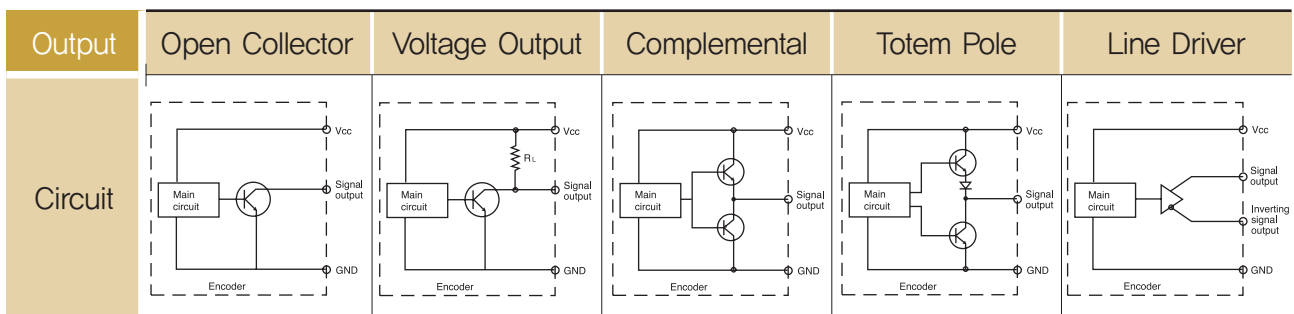

Electrical Spec.

Output type	Open Collector	Voltage Output	Complemental	Totem Pole	Line Driver
Power Supply	DC +5[V] ~ +24[V] Ripple p-p : less than 5%	DC +5[V] ~ +24[V] Ripple p-p : less than 5%	DC +15[V], +24[V] Ripple p-p : less than 5%	DC +5[V] ~ 24[V] Ripple p-p : less than 5%	DC +5[V] Ripple p-p : less than 5%
Consuming Current (In case of no load)	70mA Max	70mA Max	150mA Max	150mA Max	150mA Max
Maximum Response Frequency	150 KHz (10 ~ 2048 P/R) / 300 KHz (2500 ~ 6000 P/R)				
Output voltage	Less than $V_i \cdot 0.5[V]$ / More than $V_i \cdot 2.5[V]$ (In case of inputting +5V) / More than $V_i \cdot 10[V]$ (In case of inputting +15V) / More than $V_i \cdot 18[V]$ (In case of inputting +24V)				
Output current	Less than 20mA	Less than 20mA	Less than 10mA	Less than 10mA	Less than 20mA
Rising, decline time	Less than 3 μ s	Less than 3 μ s	Less than 1 μ s	Less than 1 μ s	Less than 0,1 μ s
Common conditions	In case that the cable length of output side is 1[M] and load resistance is less than 1[k Ω]				

※ In case of more than 5,000P/R, the input power should be +5[V]~+15[V](Except Line driver)

Mechanical Spec.

Starting Torque	80gf – cm Max
Maximum number of revolution	6000 rpm
Bearing lifetime	27,000[hr](In case of rotating by 5000rpm)
Allowable Shaft Load	Radial : 2.5kg Max Axial : 1.3kg Max
Position deflection of allowable shaft	Radial : Less than 0,05 mm Axial : Less than 0,2mm
Connection Table	4P(AWG26) Shield CABLE
weight	206g

Rigid Spec.

Operating Temp. Range	-10°C ~ +70°C (No freezing)
Preserving temp	-20°C ~ +85°C
Using humidity	35% ~ 85% RH
Preserving Humidity	30% ~ 90% RH
Internal Vibration	5G
Internal Shock	100G
Degree of Protection	IP 50

Output Phase Shift

CW → Clockwise viewed from shaft end
 $a + b, c + d = T/2 \pm T/10$
 $a, b, c, d = T/4 \pm T/10$



Open Collector, Voltage Output Complemental, Totem Pole

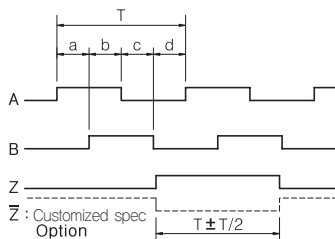

Line Driver

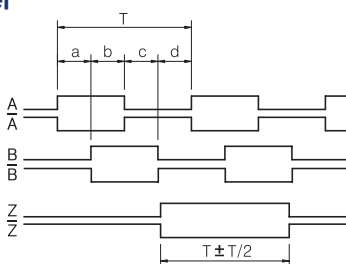

Connection Table

Cable's Color	Connection Table	
	Open Collector Voltage Output Complemental Totem Pole	Line Driver
Red	Vcc	Vcc
Black	GND	GND
Green	A Sig	A Sig
Blue	-	\bar{A} Sig
White	B Sig	B Sig
Pink	-	\bar{B} Sig
Yellow	Z Sig	Z Sig
Orange	-	\bar{Z} Sig
Shield	CASE Shield	CASE Shield

INCREMENTAL SHAFT TYPE S68A Series

- Features : Machine tools, Industrial robot,
Rigid shaft type (Industrial robot),
Various resolution

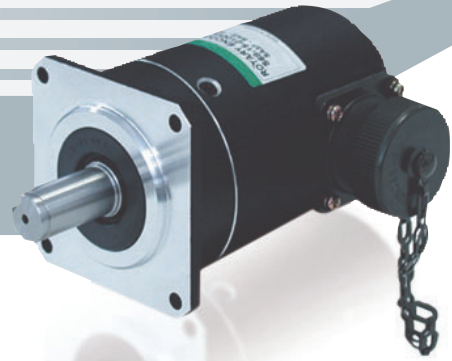

Model

INCREMENTAL
SHAFT TYPE
Outer Diameter $\varnothing 68$

Shaft Size

15 : $\varnothing 15$

S68A - 15 -

Resolution(P/R)

0100 1000 1024
2000 2048

Output Signal

Z : A, B, Z
U : A, \bar{A} , B, \bar{B}
V : A, \bar{A} , B, \bar{B} , Z, \bar{Z}

Output Form

O : Open Collector
V : Voltage Output
T : Totem Pole
L : Line Driver



The spec. of power may be different depending on the type of output and be sure to check the electric spec.

External Dimension

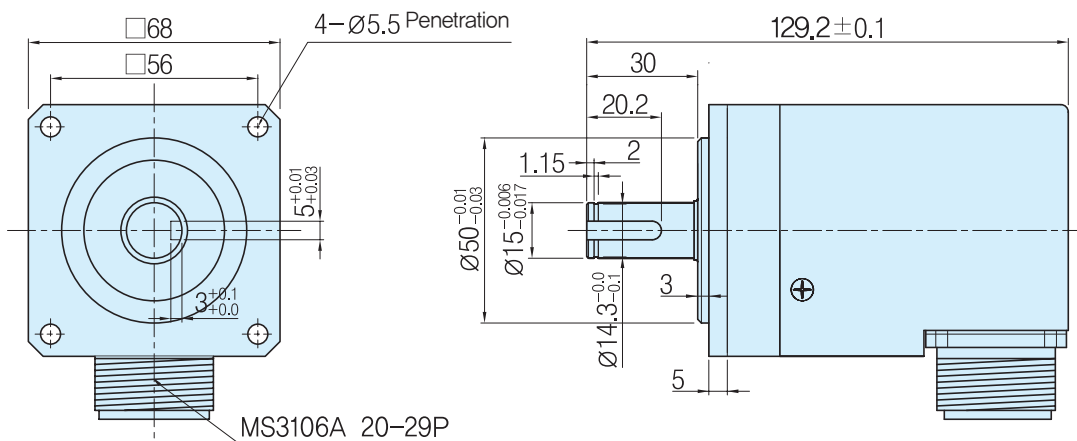

Output Circuit

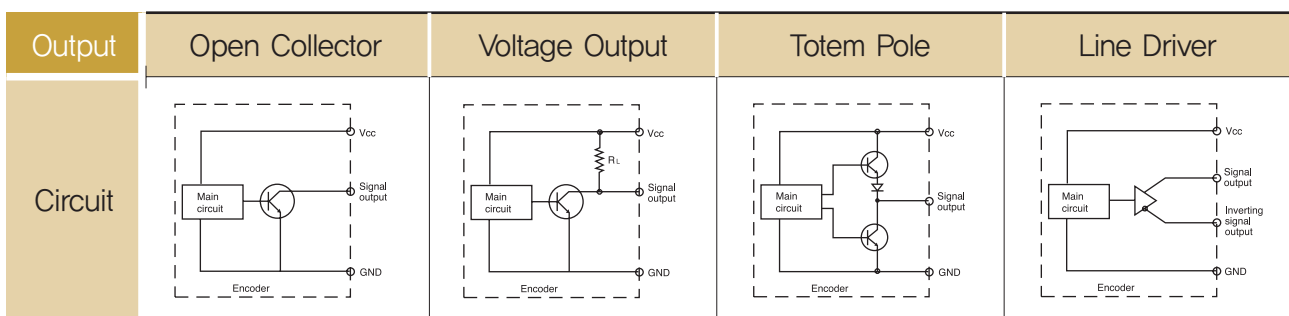

Electrical Spec.

Output type	Open Collector	Voltage Output	Totem Pole	Line Driver
Power Supply	DC +15[V] Ripple p-p : less than 5%	DC +15[V] Ripple p-p : less than 5%	DC +5[V] ~ 24[V] Ripple p-p : less than 5%	DC +5[V] Ripple p-p : less than 5%
Consuming Current (In case of no load)	70mA Max	70mA Max	150mA Max	150mA Max
Maximum Response Frequency	150 KHz (100 ~ 2048 P/R)			
Output voltage	Less than $V_i \cdot 0.5[V]$ / More than $V_i \cdot 2.5[V]$ (In case of inputting +5V), / More than $V_i \cdot 10[V]$ (In case of inputting +15V) / More than $V_i \cdot 18[V]$ (In case of inputting +24V)			
Output current	Less than 20mA	Less than 20mA	Less than 10mA	Less than 20mA
Rising, decline time	Less than 3 μ s	Less than 3 μ s	Less than 1 μ s	Less than 0.1 μ s
Common conditions	In case that the cable length of output side is 1[M] and load resistance is less than 1[k Ω]			

Mechanical Spec.

Starting Torque	800gf – cm Max
Maximum number of revolution	8000 rpm
Bearing lifetime	100,000[hr](In case of rotating by 6000rpm)
Allowable Shaft Load	Radial : 5kg Max Axial : 5kg Max
Position deflection of allowable shaft	Radial : Less than 0.05 mm Axial : Less than 0.2mm
Connection Table	MS3102A 20-29P
weight	720g

Rigid Spec.

Operating Temp. Range	-10°C ~ +70°C (No freezing)
Preserving temp	-20°C ~ +85°C
Using humidity	35% ~ +85% RH
Preserving Humidity	35% ~ +95% RH
Internal Vibration	5G
Internal Shock	50G
Degree of Protection	IP 54

Output Phase Shift

CW → Clockwise viewed from shaft end
 $a + b, c + d = T/2 \pm T/10$
 $a, b, c, d = T/4 \pm T/10$



Open Collector, Voltage Output Totem Pole

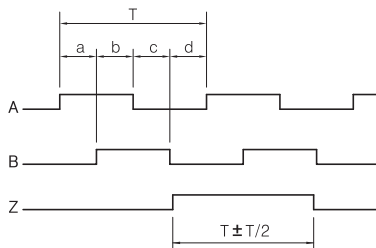

Line Driver

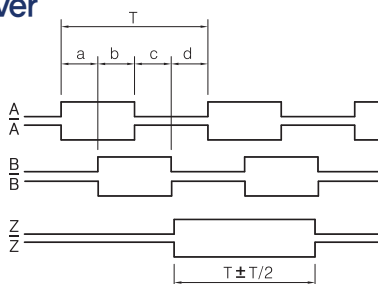

Connection Table

Cable's Color	Connection Table	
Pin code	Open Collector Voltage Output Totem Pole	Line Driver
H	Vcc	Vcc
K,M	GND	GND
A	A Sig	A Sig
N	-	\bar{A} Sig
C	B Sig	B Sig
R	-	\bar{B} Sig
B	Z Sig	Z Sig
P	-	\bar{Z} Sig
T	CASE Shield	CASE Shield

INCREMENTAL HOLLOW TYPE H40 Series

- Features : Various resolution, 10~3600 P/R(21 class)
Wide ranging power voltage, Customized design,
Prompt delivery

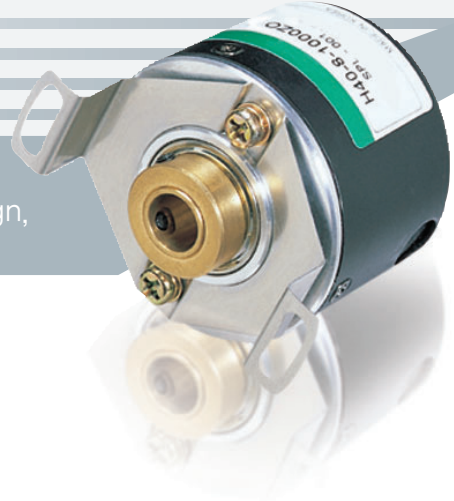

Model

INCREMENTAL
HOLLOW TYPE
Outer Diameter $\varnothing 40$

Shaft Size

■ 8 : $\varnothing 8$ ※Option: 5 : $\varnothing 5$ / 6 : $\varnothing 6$

H40 - 8 -



Resolution(P/R)

- 0010 0030 0048 0050 0100
- 0125 0200 0250 0256 0300
- 0360 0500 0512 0600 1000
- 1024 2000 2048 2500 3000
- 3600

Output Signal

- B : A, B
- Z : A, B, Z
- U : A, \bar{A} , B, \bar{B}
- V : A, \bar{A} , B, \bar{B} , Z, \bar{Z}

Output Form

- O : Open Collector
- V : Voltage Output
- C : Complemental
- T : Totem Pole
- L : Line Driver

Cable Length

- 1 : 1[M]
- 2 : 3[M]
- 3 : 5[M]
- 4 : 10[M]



The spec. of power may be different depending on the type of output and be sure to check the electric spec.

External Dimension

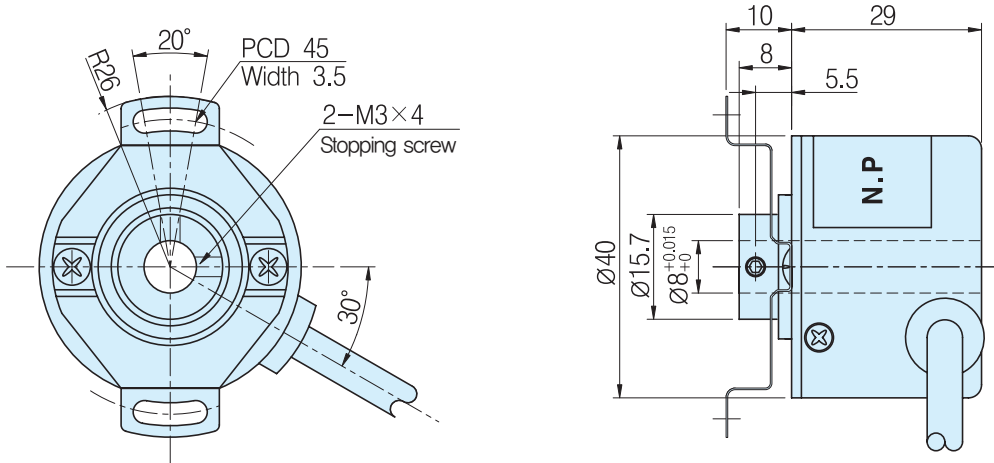

Output Circuit

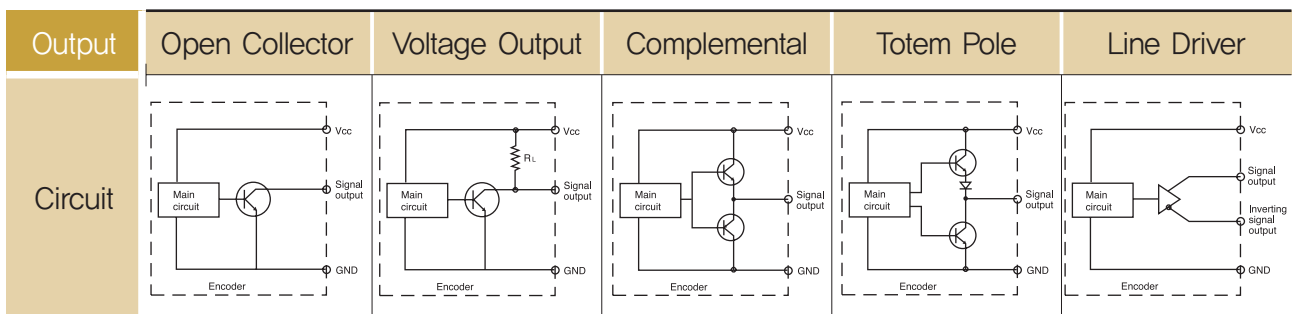

Electrical Spec.

Output type	Open Collector	Voltage Output	Complemental	Totem Pole	Line Driver
Power Supply	DC +5[V] ~ +24[V] Ripple p-p : less than 5%	DC +5[V] ~ +24[V] Ripple p-p : less than 5%	DC +15[V], +24[V] Ripple p-p : less than 5%	DC +5[V] ~ 15[V], +24[V] Ripple p-p : less than 5%	DC +5[V], +5~24[V] Ripple p-p : less than 5%
Consuming Current (In case of no load)	70mA Max	70mA Max	150mA Max	150mA Max	150mA Max
Maximum Response Frequency	150 KHz (10 ~ 2048 P/R) / 300 KHz (2500 ~ 3600 P/R)				
Output voltage	Less than $V_i \cdot 0.5[V]$ / More than $V_i \cdot 2.5[V]$ (In case of inputting +5V), / More than $V_i \cdot 10[V]$ (In case of inputting +15V) / More than $V_i \cdot 18[V]$ (In case of inputting +24V)				
Output current	Less than 20mA	Less than 20mA	Less than 10mA	Less than 10mA	Less than 20mA
Rising, decline time	Less than 3 μ s	Less than 3 μ s	Less than 1 μ s	Less than 1 μ s	Less than 0,1 μ s
Common conditions	In case that the cable length of output side is 1[M] and load resistance is less than 1[k Ω]				

Mechanical Spec.

Starting Torque	80gf - cm Max
Maximum number of revolution	6000 rpm
Bearing lifetime	27,000[hr](In case of rotating by 5000rpm)
Allowable Shaft Load	Radial : 2.5kg Max Axial : 1.3kg Max
Position deflection of allowable shaft	Radial : Less than 0,05 mm Axial : Less than 0,2mm
Connection Table	4P(AWG26) Shield CABLE
weight	150g

Rigid Spec.

Operating Temp. Range	-10°C ~ +70°C (No freezing)
Preserving temp	-20°C ~ +85°C
Using humidity	35% ~ 80% RH
Preserving Humidity	30% ~ 85% RH
Internal Vibration	5G
Internal Shock	50G
Degree of Protection	IP 50

Output Phase Shift

CW \Rightarrow Clockwise viewed from shaft end
 $a + b, c + d = T/2 \pm T/10$
 $a, b, c, d = T/4 \pm T/10$



Open Collector, Voltage Output Complemental, Totem Pole

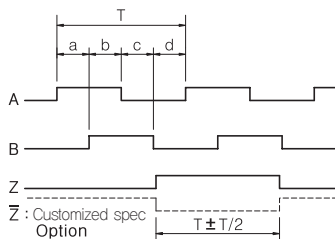

Line Driver

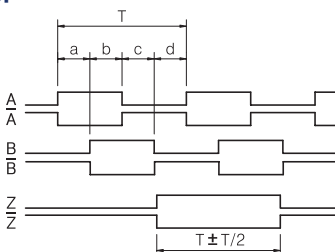

Connection Table

Cable's Color	Connection Table	
Output Form	Open Collector Voltage Output Complemental Totem Pole	Line Driver
Red	Vcc	Vcc
Black	GND	GND
Green	A Sig	A Sig
Blue	-	\bar{A} Sig
White	B Sig	B Sig
Pink	-	\bar{B} Sig
Yellow	Z Sig	Z Sig
Orange	-	\bar{Z} Sig
Shield	CASE Shield	CASE Shield

INCREMENTAL
HOLLOW TYPE

H88-30C Series

- Features : Elevator, Parking system, Industrial motor
- Easy to be attached, Customized design,
- Prompt delivery

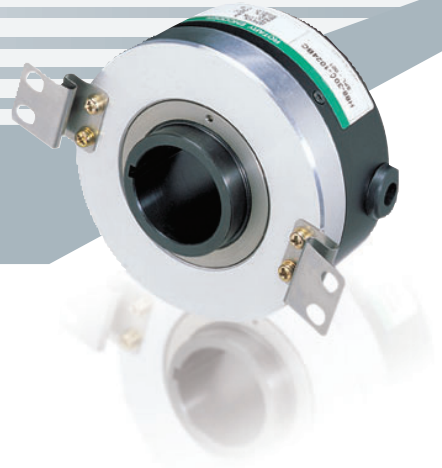

Model

INCREMENTAL
HOLLOW TYPE
Outer Diameter Ø88

Shaft Size

30 : Ø30

H88-30C-

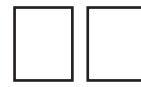

Resolution(P/R)

0512 1024

Output Signal

- B : A, B
- Z : A, B, Z
- V : A, \bar{A} , B, \bar{B} , Z, \bar{Z}

Output Form

- O : Open Collector
- C : Complemental
- L : Line Driver

Cable Length

- 1 : 1[M]
- 2 : 3[M]
- 3 : 5[M]
- 4 : 10[M]



The spec. of power may be different depending on the type of output and be sure to check the electric spec.

External Dimension

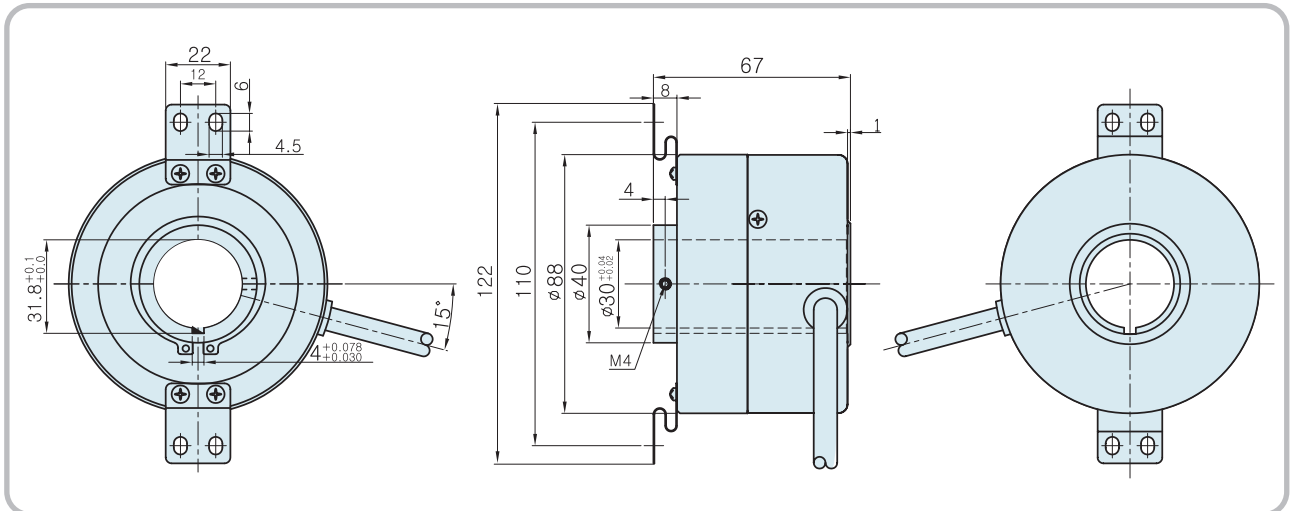

Output Circuit

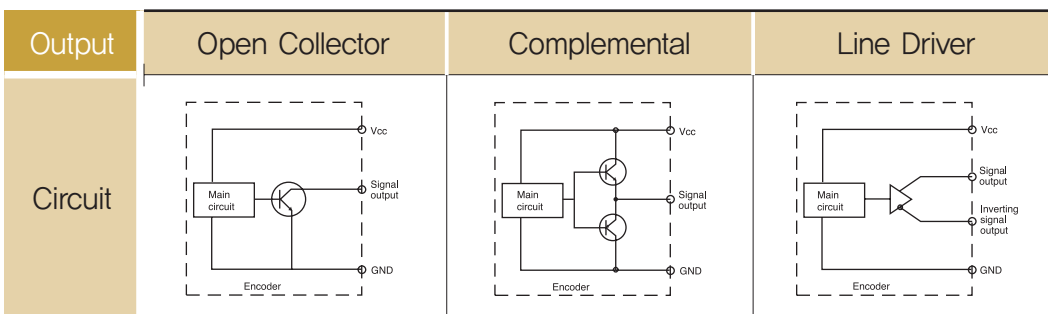

Electrical Spec.

Output type	Open Collector	Complemental	Line Driver
Power Supply	DC +15[V] Ripple p-p : less than 5%	DC +15[V] Ripple p-p : less than 5%	DC +5[V], +5~24[V] Ripple p-p : less than 5%
Consuming Current (In case of no load)	70mA Max	150mA Max	150mA Max
Maximum Response Frequency	150 KHz		
Output voltage	Less than V_L 0.5[V] / More than V_H 2.5[V] (In case of inputting +5V), /More than V_H 10[V](In case of inputting +15V)		
Output current	Less than 20mA	Less than 10mA	Less than 20mA
Rising, decline time T_R / T_F	Less than 3 μ s	Less than 1 μ s	Less than 0.1 μ s
	In case that the cable length of output side is 1[M] and load resistance is less than 1[k Ω]		

Mechanical Spec.

Starting Torque	800gf – cm Max
Maximum number of revolution	3000 rpm
Bearing lifetime	50,000[hr](In case of rotating by 3000rpm)
Allowable Shaft Load	Radial : 5.0kg Max Axial : 2.5kg Max
Position deflection of allowable shaft	Radial : Less than 0.05 mm Axial : Less than 0.2mm
Connection Table	4P(AWG26) Shield CABLE
weight	600g

Rigid Spec.

Operating Temp. Range	-10°C ~ +70°C (No freezing)
Preserving temp	-20°C ~ +85°C
Using humidity	35% ~ 80% RH
Preserving Humidity	30% ~ 85% RH
Internal Vibration	5G
Internal Shock	100G
Degree of Protection	IP 50

Output Phase Shift

CW \rightarrow Clockwise viewed from shaft end
 $a + b, c + d = T/2 \pm T/10$
 $a, b, c, d = T/4 \pm T/10$

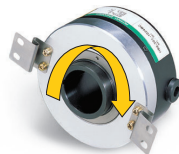

Open Collector, Voltage Output Complemental, Totem Pole

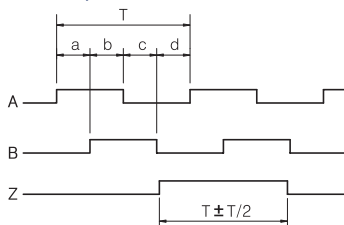

Line Driver

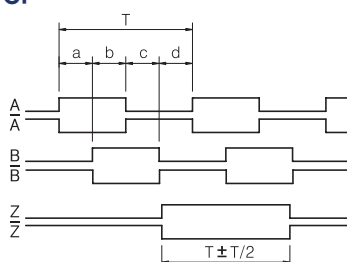

Connection Table

Cable's Color	Connection Table	
	Open Collector Voltage Output Complemental	Line Driver
Red	Vcc	Vcc
Black	GND	GND
Green	A Sig	A Sig
Orange	A Sig GND	\bar{Z} Sig
Yellow	B Sig	Z Sig
White	B Sig GND	B Sig
Blue	-	\bar{A} Sig
Pink	-	\bar{B} Sig
Shield	CASE Shield	CASE Shield

INCREMENTAL
HOLLOW TYPE

H100 Series

- Features : Elevator, Parking system, Industrial motor
- Easy to be attached, Customized design, prompt delivery

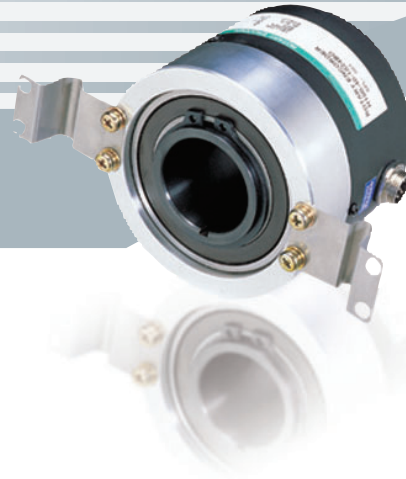

Model

INCREMENTAL
HOLLOW TYPE
Outer Diameter Ø100

Shaft Size

40 : Ø40

H100-40- **-** **-** **7[M]**

Resolution(P/R)

0512 1024

Output Signal

B : A, B
U : A, \bar{A} , B, \bar{B}

Output Form

O : Open Collector
T : Totem Pole
L : Line Driver

Cable Length



The spec. of power may be different depending on the type of output and be sure to check the electric spec.

External Dimension

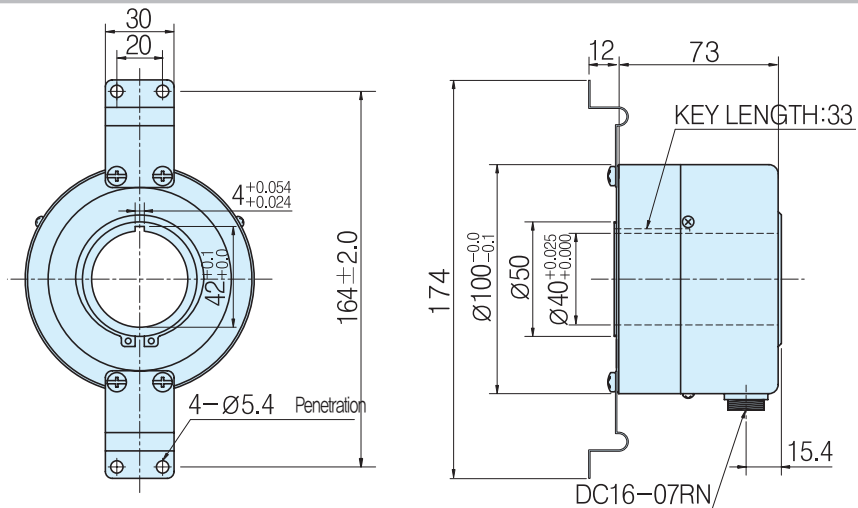

Output Circuit

Output	Open Collector	Totem Pole	Line Driver
Circuit			

Electrical Spec.

Output type	Open Collector	Totem Pole	Line Driver
Power Supply	DC +5[V] Ripple p-p : less than 5%	DC +15[V] Ripple p-p : less than 5%	DC +5[V] Ripple p-p : less than 5%
Consuming Current (In case of no load)	70mA Max	150mA Max	150mA Max
Maximum Response Frequency	150 KHz		
Output voltage	Less than V_L 0.5[V] / More than V_H 2.5[V] (In case of inputting +5V), /More than V_H 10[V](In case of inputting +15V)		
Output current	Less than 20mA	Less than 10mA	Less than 20mA
Rising, decline time	Less than 3 μ s	Less than 1 μ s	Less than 0.1 μ s
Common conditions	In case that the cable length of output side is 1[M] and load resistance is less than 1[k Ω]		

Mechanical Spec.

Starting Torque	800gf – cm Max
Maximum number of revolution	3000 rpm
Bearing lifetime	50,000[hr](In case of rotating by 3000rpm)
Allowable Shaft Load	Radial : 5.0kg Max Axial : 2.5kg Max
Position deflection of allowable shaft	Radial : Less than 0.05 mm Axial : Less than 0.2mm
Connection Table	3P(AWG26) Shield CABLE
weight	1.2kg

Rigid Spec.

Operating Temp. Range	-10°C ~ +70°C (No freezing)
Preserving temp	-20°C ~ +85°C
Using humidity	35% ~ 80% RH
Preserving Humidity	30% ~ 85% RH
Internal Vibration	5G
Internal Shock	100G
Degree of Protection	IP 50

Output Phase Shift

CCW \rightarrow Counterclockwise viewed from shaft end

$$a + b, c + d = T/2 \pm T/10$$

$$a, b, c, d = T/4 \pm T/10$$

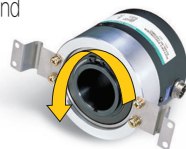

Open Collector, Totem Pole

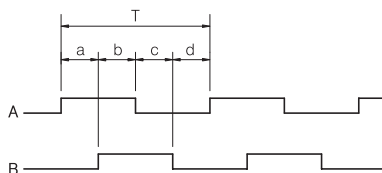

Line Driver

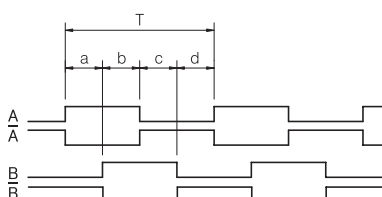

Connection Table

PIN NO	Cable's Color	Connection Table	
		Open Collector Totem Pole	Line Driver
1	Red	Vcc	Vcc
2	Black	GND	GND
3	Green	A Sig	A Sig
4	Orange	A Sig GND	\bar{A} Sig
5	Brown	B Sig	B Sig
6	White	B Sig GND	\bar{B} Sig
7	Shield	CASE Shield	CASE Shield

MANUAL PULSE GENERATOR

SM60 Series

- Features : NC tooling machine, Industrial application
- High reliability, Customized logo can be available
- Half permanent durability



Model

MANUAL
PULSE GENERATOR
Outer Diameter Ø60

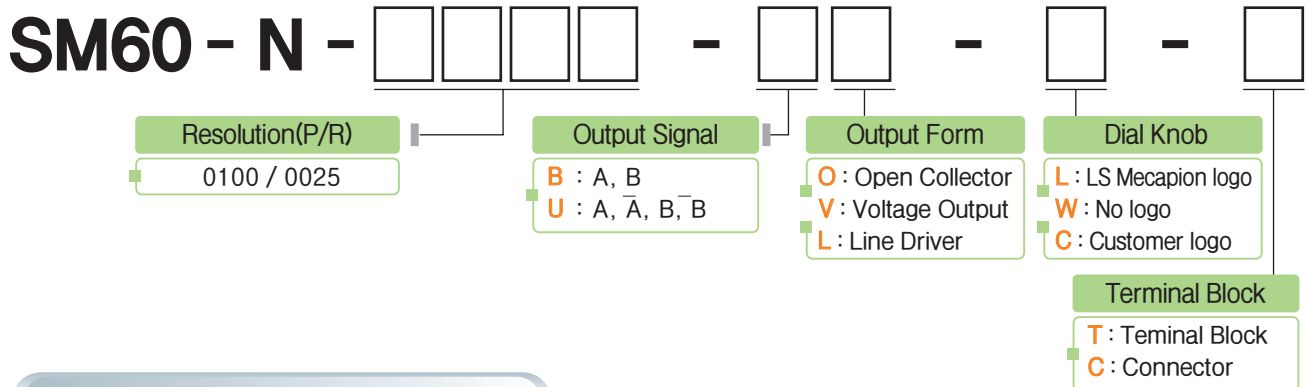

External Dimension

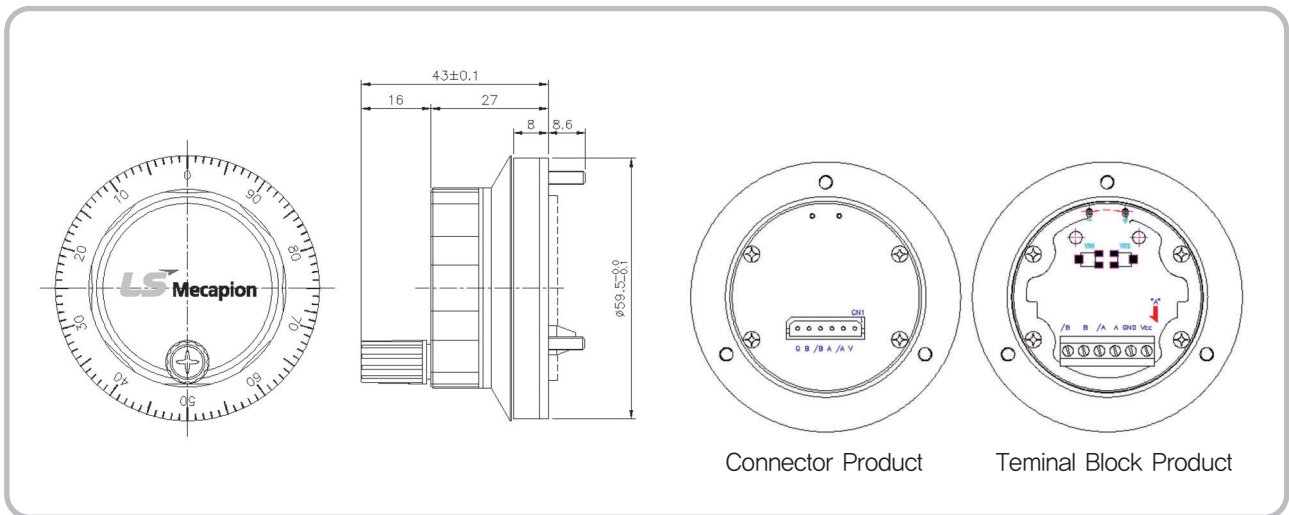

Output Circuit

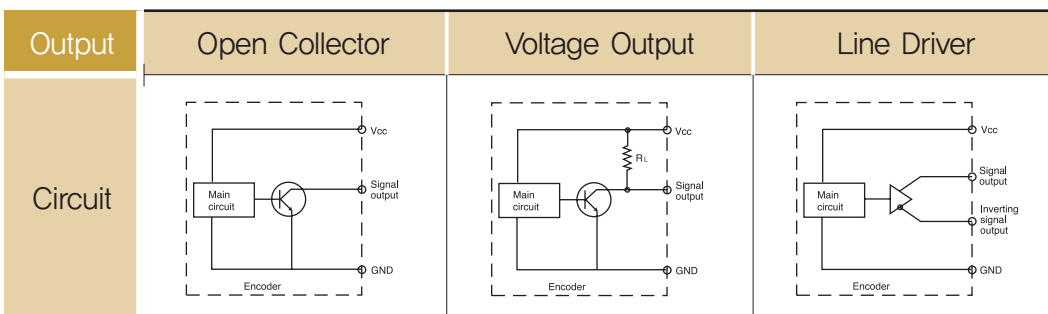

Electrical Spec.

Output type	Open Collector	Voltage Output	Line Driver
Power Supply	DC +12[V]~+15[V] Ripple p-p : less than 5%		DC +5[V] Ripple p-p : less than 5%
Consuming Current (In case of no load)	70mA Max	70mA Max	150mA Max
Maximum Response Frequency	5 KHz MAX	5 KHz MAX	5 KHz MAX
Output voltage	Less than V_L 0.5[V] / More than V_H 2.5[V]		Less than V_L 0.5[V] / More than V_H 2.5[V]
Output current	Less than 20mA	Less than 20mA	Less than 20mA
Rising, decline time	Less than 3 μ s	Less than 3 μ s	Less than 0.1 μ s
Common conditions	In case that the cable length of output side is 1[M] and load resistance is less than 1[k Ω]		

Mechanical Spec.

Starting Torque	500gf - cm Max
Maximum number of revolution	600 rpm
Bearing lifetime	80,000[hr](In case of rotating by 200rpm)
Connection Table	SL-001V
weight	150g

Rigid Spec.

Operating Temp. Range	-10°C ~ +70°C (No freezing)
Preserving temp	-20°C ~ +85°C
Using humidity	35% ~ 80% RH
Preserving Humidity	30% ~ 85% RH
Internal Vibration	5G
Internal Shock	50G
Degree of Protection	IP 50

Output Phase Shift

CW \Rightarrow Clockwise viewed from shaft end

$$a + b, c + d = T/2 \pm T/8$$

$$a, b, c, d = T/4 \pm T/8$$



Open Collector, Voltage Output

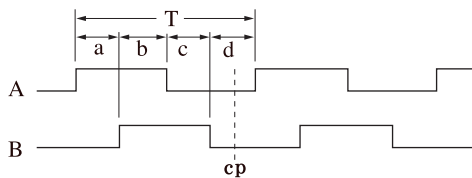

Line Driver

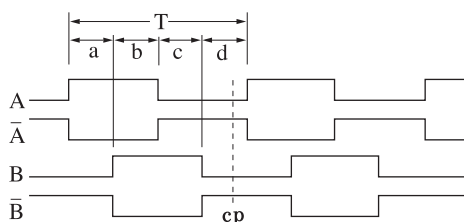

Connection Table

/B	B	/A	A	GND	VCC

No.	Cable Configuration	
	Open Collector Voltage Output	Line Driver
1	Vcc	Vcc
2	Gnd	Gnd
3	A	A
4	-	/A
5	B	B
6	-	/B

MANNUAL PULSE GENERATOR **SM80 Series**

- Features : NC tooling machine, Industrial application
- High reliability, Customized logo can be available
- Half permanent durability



Model

MANNUAL
PULSE GENERATOR
Outer Diameter Ø80

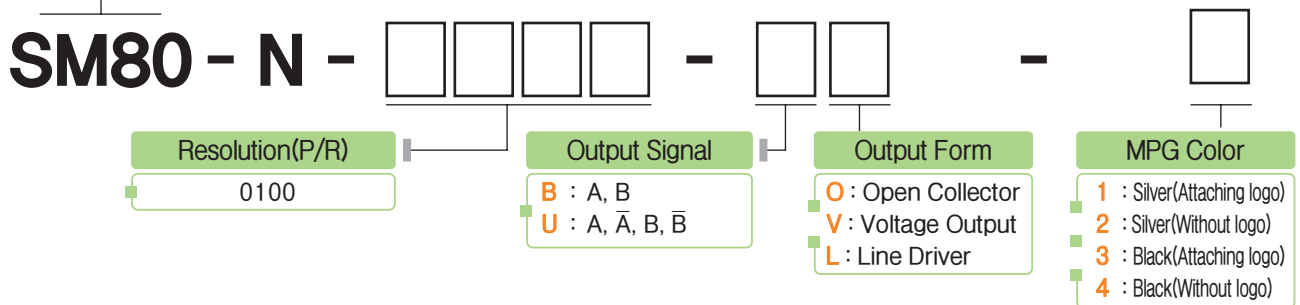

External Dimension

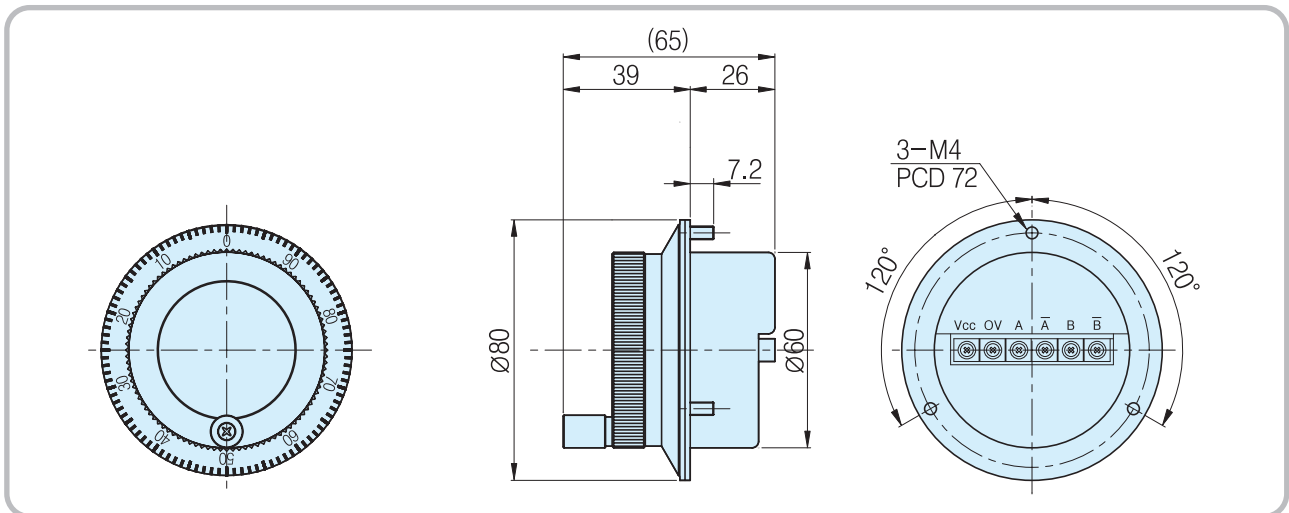

Output Circuit

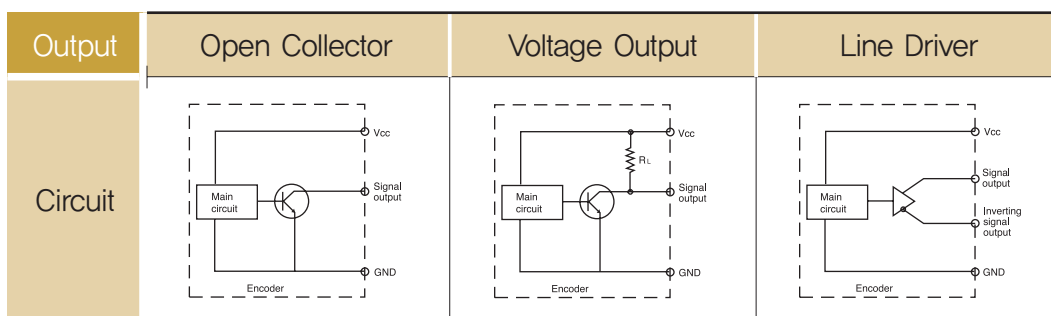

Electrical Spec.

Output type	Open Collector	Voltage Output	Line Driver
Power Supply	DC +5[V] Ripple p-p : less than 5%		
Consuming Current (In case of no load)	70mA Max	70mA Max	150mA Max
Maximum Response Frequency	5 KHz MAX	5 KHz MAX	5 KHz MAX
Output voltage	Less than V_L 0.5[V] / More than V_H 2.5[V]		
Output current	Less than 20mA	Less than 20mA	Less than 20mA
Rising, decline time	Less than 0.1 μ s	Less than 0.1 μ s	Less than 0.1 μ s
Common conditions	In case that the cable length of output side is 1[M] and load resistance is less than 1[k Ω]		

Mechanical Spec.

Starting Torque	600gf - cm Max
Maximum number of revolution	600 rpm
Bearing lifetime	50,000[hr](In case of rotating by 600rpm)
Connection Table	6P board
weight	600g

Output Phase Shift

CW \Rightarrow Clockwise viewed from shaft end

$$a + b, c + d = T/2 \pm T/8$$

$$a, b, c, d = T/4 \pm T/8$$



Open Collector, Voltage Output

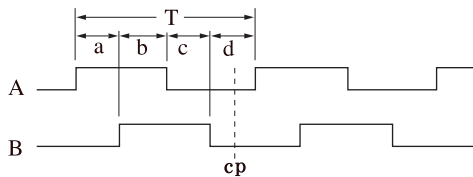

Line Driver

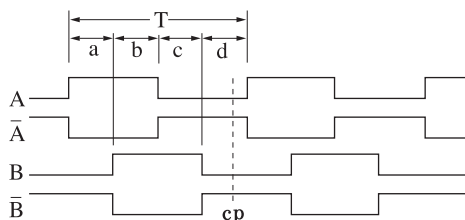

Color	Silver	Black
The logo by color can be attached and detached		

Rigid Spec.

Operating Temp. Range	-10°C ~ +70°C (No freezing)
Preserving temp	-20°C ~ +85°C
Using humidity	35% ~ 80% RH
Preserving Humidity	30% ~ 85% RH
Internal Vibration	5G
Internal Shock	50G
Degree of Protection	IP 50

Connection Table

Cable Configuration

Open Collector, Voltage Output

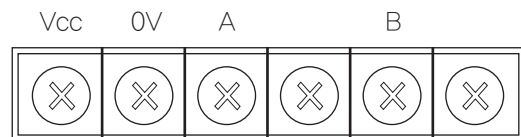

Line Driver

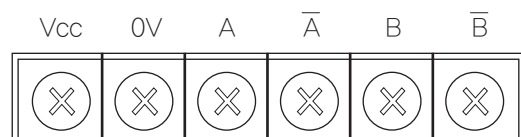

SPM Series

- Features : NC tooling machine, Industrial application
- High reliability, Customized logo can be available
- Half permanent durability



Model

Output Form

L : Line Driver

SPM - S01 - A - L - M - 1

Spec

- S01 : Standard
- S02 : Standard + EMG + Enable
- S03 : Standard + EMG
- S04 : Standard + Enable

IP Grade

- A : IP 50
- B : IP 65

Magnet

- M : With Magnet
- O : Without Magnet

Cable Length

- 1 : 0.7m(4.1m)
- 2 : 1.0m(5.3m)

• *Note) S/W Spec
Axes : 3axes(OFF,X,Y,Z)
Multipulation : X1, X10, X100
Enable S/W : OR type

External Dimension

〈Standard+EMG+ENA Type〉

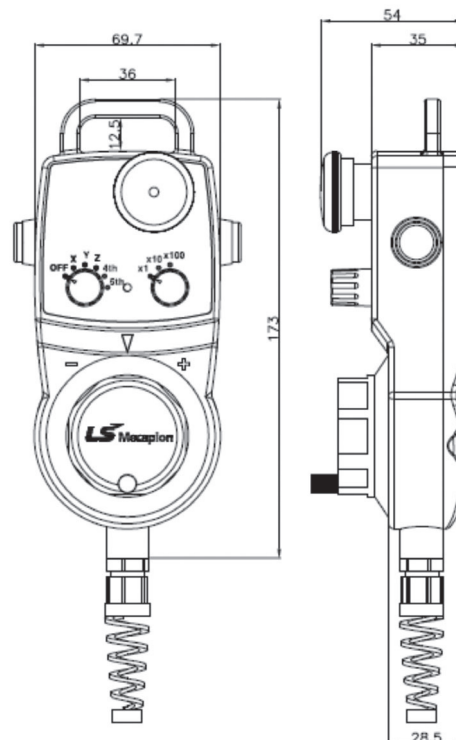

Electrical Spec.

Output type	Line Driver		
Power Supply	DC +5[V]		
Consuming Current (In case of no load)	50mA Max		
Maximum Response Frequency	5 KHz MAX		
Output voltage	Less than V_L 0.5[V] / Over than V_H 2.5[V]	Multipulation	X1, X10, X100 (Rotary Switch)
Output current	Less than 20mA		Emergency S/W
Rising, decline time	Less than 0.1 μ s	S/W	Enable S/W
Axis	X, Y, Z		JOG S/W

Mechanical Spec.

Starting Torque	200gf – cm Max
Maximum number of revolution	600 rpm
Bearing lifetime	50,000[hr]
Terminal Block	5268-6(Molex)
Magnet	With / Without
Material	ABS

Rigid Spec.

Operating Temp. Range	-10°C ~ +70°C
Preserving temp	-20°C ~ +85°C
Using humidity	35% ~ 80% RH
Preserving Humidity	30% ~ 85% RH
Internal Vibration	5G
Internal Shock	10G
Degree of Protection	A Type: IP 50 / B Type: IP 65

Output Phase Shift

Line Driver

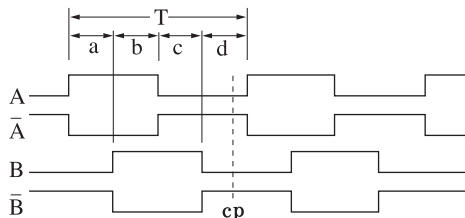

Output Circuit

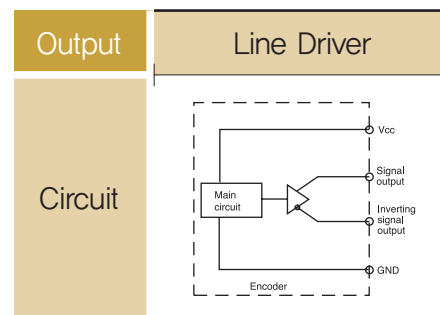

Connection Table

Wiring Diagram

NO.	Signal	Color	Remarks
1	H+5V	Red	MANUAL PULSE GENERATOR
2	H0V	Black	
3	HA	White	
4	HB	Brown	
5	/HA	Yellow	
6	/HB	Gray	
7	COM	Pink	COM
8	AX1	Blue	AXIS SWITCH SELECTING
9	AX2	Violet	
10	AX4	Green	
11	MP1	Red/Blue	Rate SELECTING
12	MP2	White/Green	
13	L+	Gray/Pink	LED
14	L-	White/Gray	
15	RES1	White/Yellow	EMERGENCY STOP
16	RES2	Yellow/Brown	
17	EN1	Gray/Brown	ENABLE
18	EN2	Brown/Green	
19	Shield	Case Shield	

(Standard+EMG+ENA Type)

Coupling

Option

Plastic coupling

Model	A	B	D	L
P6-6	ø6	ø6	ø15	21.6
P8-8	ø8	ø8	ø19	24

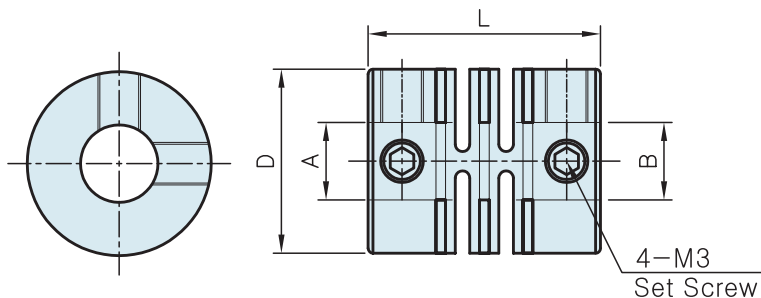

Helical coupling

Model	A	B	D	L
H6-6	ø6	ø6	ø19	22.2
H8-8	ø8	ø8	ø22.2	22.2
H6-10	ø6	ø10	ø22.2	22.2
H6-10	ø8	ø10	ø22.2	22.2

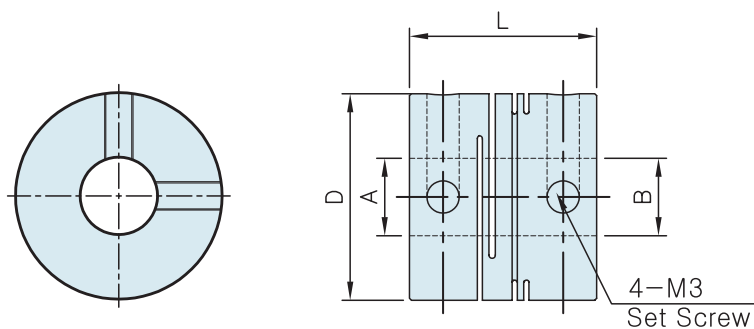

Disk coupling

Model	A	B	D	L
D6-6	ø6	ø6	ø26	22.5
D8-8	ø8	ø8	ø26	22.5
D6-10	ø6	ø10	ø26	22.5
D8-10	ø8	ø10	ø26	22.5

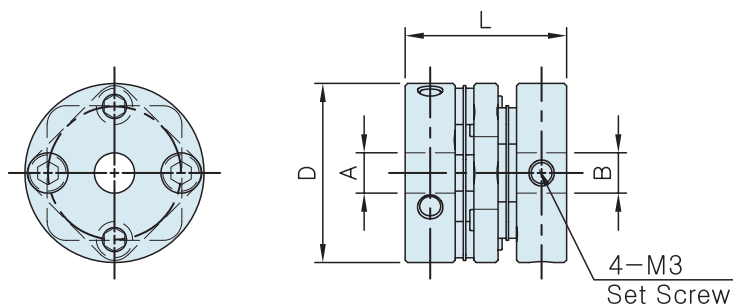

LS Mecapion

www.lsmecapion.com



Safety Instructions

- For your safety, please read user's manual thoroughly before operating.
- Contact the nearest authorized service facility for examination, repair, or adjustment.
- Please contact qualified service technician when you need maintenance.
Do not disassemble or repair by yourself!
- Any maintenance and inspection shall be performed by the personnel having expertise concerned.

Head Office & Plant

(Hightech Industrial Park) 8-4, Hosandong-ro 12-9,
Dalseo-Gu, Daegu, Korea 704-240
T 82-53-593-0066 F 82-53-591-8614

Kyungin Center

104-605, SK-Ventium, 522, Gosan-ro 166,
Gunpo, Gyeonggi-Do, Korea 435-776
T 82-31-436-0600 F 82-31-436-0604

China Factory

204-1, Xida Road, Meicun Industrial Center,
Xinqiu, Wuxi, Jiangsu, China
T 86-510-8295-3000 F 86-510-8295-3019

Guangzhou Office

Room 3, 12th floor, Huiye Building No.17, Dongguan Avenue,
Dongcheng district, Dongguan City, Guangdong, China
T 86-769-2332-9080/9081 F 86-769-2332-9083