

# MECHAN CONTROLS



## Installation Guide : F-SERIES Safety system

### Keep this guide for future reference

This information is designed to help suitably qualified personnel install and operate Mechan Safety equipment. Before using this product, read this guide thoroughly along with any relevant European and/or National standards e.g. Machinery Directive 2006/42/EC and it's amendments, Provision and Use of Work Equipment Regulations. Further information can be obtained from Mechan Controls Tel +44 (0)1695 722264

### Description

The F-Series safety system is a complete electronic safety switch and emergency stop button monitoring system for machine guarding applications.

The control unit can monitor up to 30 inputs (F-Series safety switches and emergency stop buttons), maintaining CAT 4 SIL 3 and PL e.

**FM1 Safety Control Module** contains the power supply regulation, dual safety contact outputs, external reset/monitoring circuit, system & gate indication, and the input for one safety switch sensor and it's volt free indicator output. The FM1 and a safety switch sensor are all that is required for a system that is monitoring one guard.

**FX1/FX2 Safety Extender Modules** connect to the FM1 to build systems monitoring more than 1 guard. By simply connecting the required number of FX1's (one guard switch input) or FX2's (two guard switch inputs) to the FM1 systems can be built to monitor up to 30 guards. The extender modules provide connections for the safety switches along with LED and volt free indicator outputs for each safety switch input.

**ESM Emergency Stop Monitor** allows the connection of dual channel Emergency stop buttons or other dual channel safety devices with volt free contact outputs. Giving indication for each input channel and overall output indication.

**F-Series Safety Switches** are solid state electronic devices with no contacts or moving parts. This provides a tamper proof safety system that can only be activated by the Mechan actuator. When energized the safety switches are continuously monitored whether the guard is opened or not.

The Safety switches are resin encapsulated into an ABS case, to provide a fully sealed, IP67 & IP69K, sensor which can withstand the most arduous of conditions. Water, dust, oil, machine vibration and even steam cleaning have little or no effect on their performance, and with a 7-10 mm switching distance they are easy to install and provide a long and reliable working life span.

### Applications

Interlocked guards where additional security required. Door locking is not required. Harsh environments where vibration, water or dust are problems. Food and Beverage packing/filling systems Dairy Pharmaceutical Paper Industry, Can Forming and Filling, (Aluminium, Steel, Plastic) Semi conductor Manufacture/Assembly.



CAT 4  
SIL 3 PL e

APPROVALS	
CE	Complies with all relevant sections of the CE marking directive
TUV	CAT 4 SIL 3 PL e
INTERNATIONAL DIRECTIVES	
Machinery Directive 2006/42/EC	
Low Voltage Directive 2014/35/EU	
Electromagnetic Compatibility Directive 2014/30/EU	
INTERNATIONAL STANDARDS	
EN ISO 13849-1	Safety of Machinery Safety related parts of control systems
EN ISO 62061	Safety of Machinery - Functional safety of safety related electrical, electronic and programmable electronic control systems
EN 60204	Safety of Machinery Electrical equipment for machines
EN 60947-5-1	Low voltage switchgear and controlgear
EN 14119	Interlocking devices associated with guards
EN 60947-5-3	Safety of Machinery Specification for low voltage switchgear and controlgear

### Declaration of Conformity

Please contact Mechan Controls.

## SAFETY CONTROL UNIT

### Mounting on 35mm DIN Rail

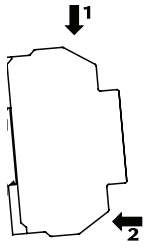

The control modules are designed to be mounted in an IP55 (minimum) control cabinet. The modules clip on to standard 35 mm symmetric (top hat) DIN-Rail

### Removal from 35mm DIN Rail

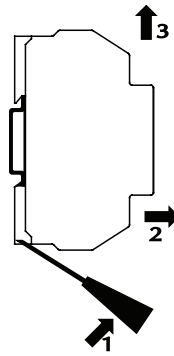

To remove the modules, gently lever out the DIN clip with a small screw-driver as shown (1). Tilt the unit in the direction (2) and slip the unit off the DIN Rail (3)

## System Assembly

Assemble the required number of modules on the DIN-Rail, starting with the FM1 and clipping the FX1, FX2 and, if required, ESM modules, to the left of the FM1.

The FM1 and FX1 monitor one safety switch each, whilst the FX2 must have 2 safety switches connected to it.

The ESM requires 2 x N/O inputs from an Emergency stop button, or other mechanical safety rated switch.

The maximum number of inputs that can be monitored by a DC supplied F-SERIES safety system is 30. The maximum number inputs that can be monitored by an AC supplied F-SERIES safety system is 10.

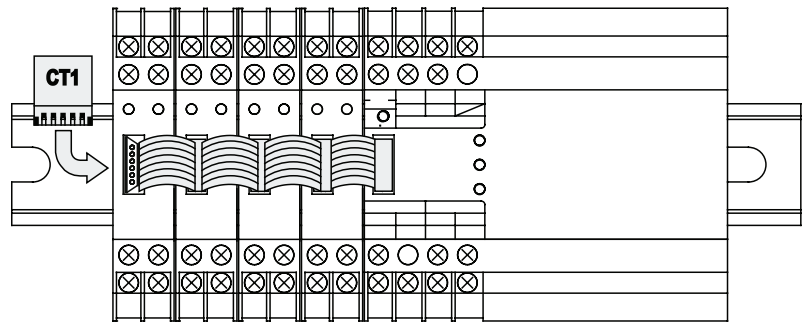

The 'Control Bus' straps on each extender unit connect to the adjacent (right hand side) module as shown. The 'Control Bus' terminator, CT1 (supplied with the FM1), must be plugged into the last extender module in the system.

## Control Modules Connections & Indication

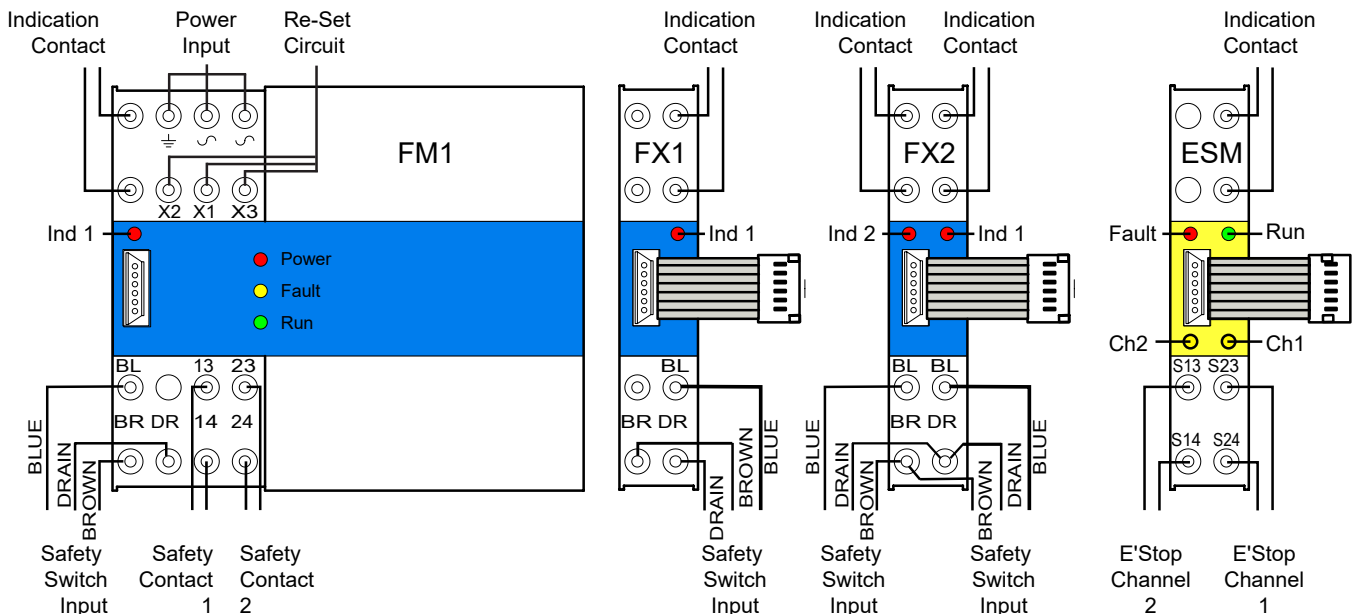

## SAFETY SWITCHES

### Mounting

Mount the switch on to the machine frame and the Actuator on to the opening edge of the door. Always try to mount the switch on non-ferrous material. (Ferrous materials may reduce the switching distance.) Use tamper proof screws to ensure additional security



Leave a minimum of 50 mm between any adjacent switches. Do not use the safety switch as a door stop.

EN 14119 Provides some mounting suggestions, see example opposite.

When fixing the safety switch to a sliding door (A), ensure that when the door is opened (B) it is not easily accessible, helping prevent the system being overridden

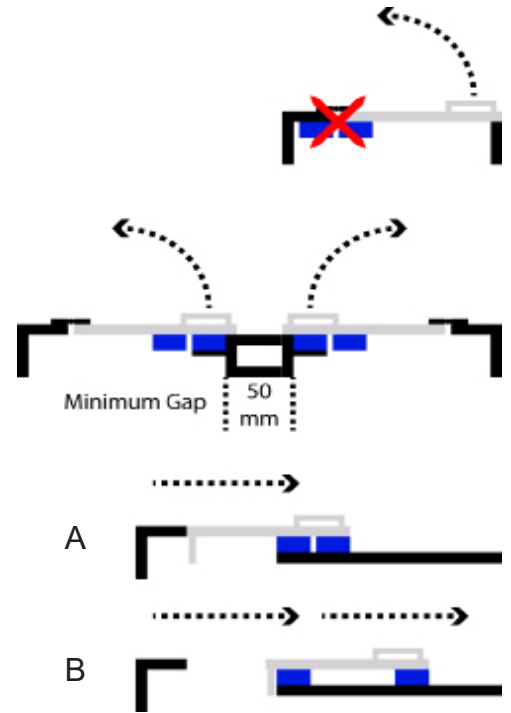

### Operation

All Mechan electronic safety switches can only be operated by the mechan actuator. They can approach each other from most angles, but when in place the targets shown in the diagrams below must be aligned and facing each other.

The R-SERIES safety switch & actuator are UNIQUELY CODED (up to 4 Billion codes) The R-SERIES Safety switch and actuator are supplied as a pair and the switch will only operate with the correct actuator. Both switch and actuator are marked with a unique code.

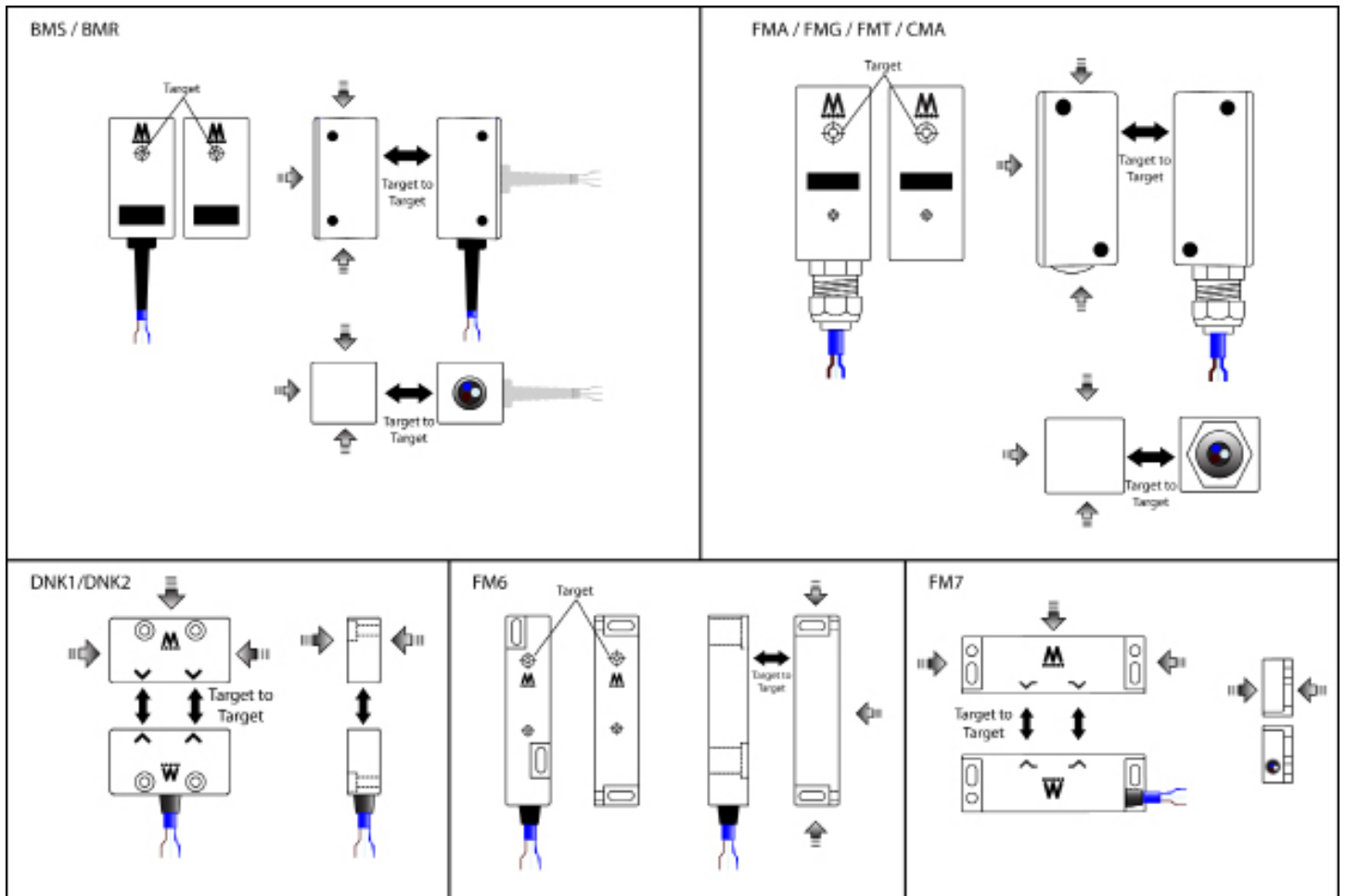

## CONNECTIONS

The Mechan fixed safety switch is supplied pre-wired with 5, 10 or 15 metres of cable encapsulated into it when manufactured. This ensures a completely water-tight seal to the electronics within the switch. Longer cables can be supplied up to maximum of 100 metres and this will not significantly affect performance.

Run the cable back to the control unit through cable protection (if required) and terminate into the appropriate input channel, following the colour coding of the wires to the label on the input terminals.

TREAT AS INSTRUMENT CABLES AND KEEP SEPARATE FROM POWER CABLES (150 mm separation is normally adequate)

If extending Mechan safety switch cables it is important to use the same type of cable, twisted pair with drain and screen. Multi-way versions of individually screened, twisted pair and drain cable may be used to run a number of sensors back to the control unit. Cable joints should be moisture proof and NOT EARTHED. The only earth connection must be via the drain terminal.

NOTE: The FX2 requires the commoning of the supply and drain wires (BROWN / DRAIN) from the two switches at the extender module as shown above.

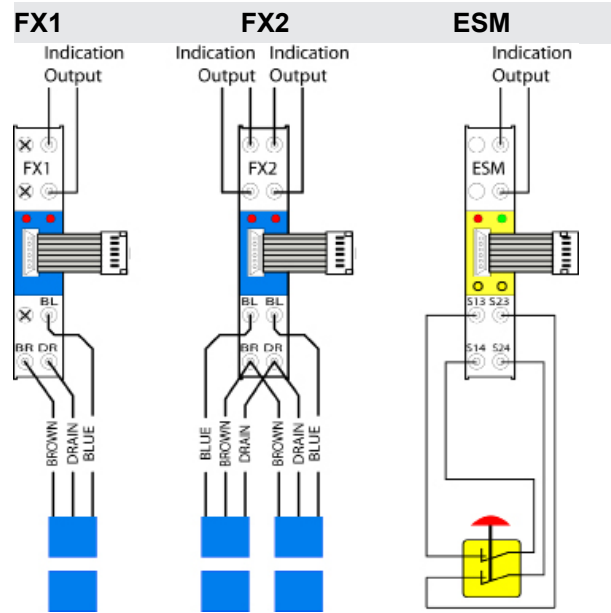

## CONNECTION FOR A SINGLE SWITCH

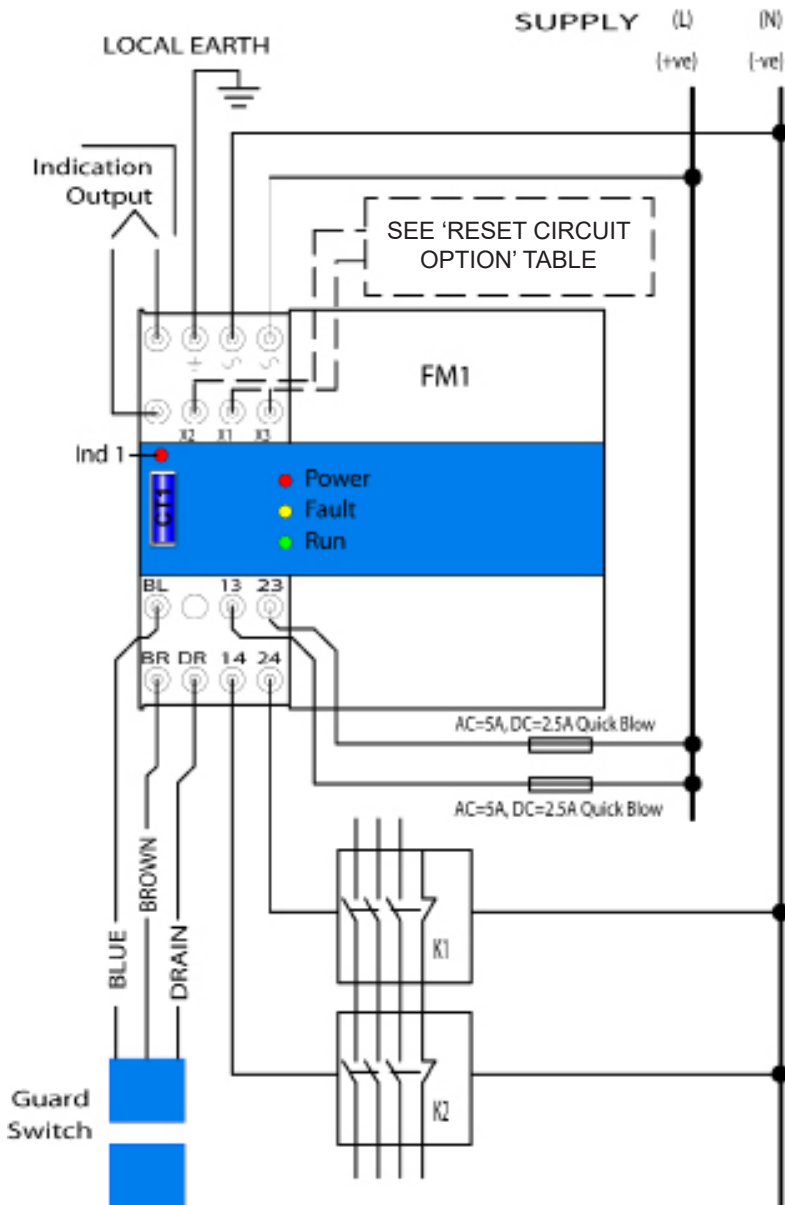

### Note :

- 1) When the unit is powered, the safety switch is closed and the re-set circuit is made the N/O safety outputs will close and the N/C indicator output will be open.
- 2) When the safety switch is opened, ( the actuator moved away from the switch) the N/O safety outputs will open and the N/C indicator output will be close.

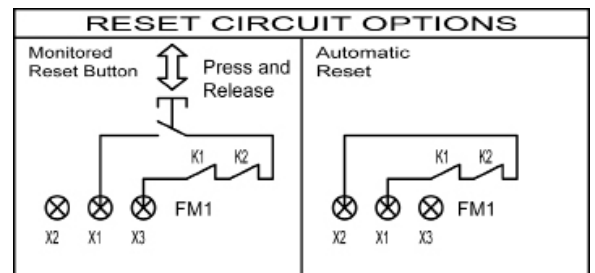

## CONNECTION FOR MULTI-GATE SYSTEM AND E'STOP

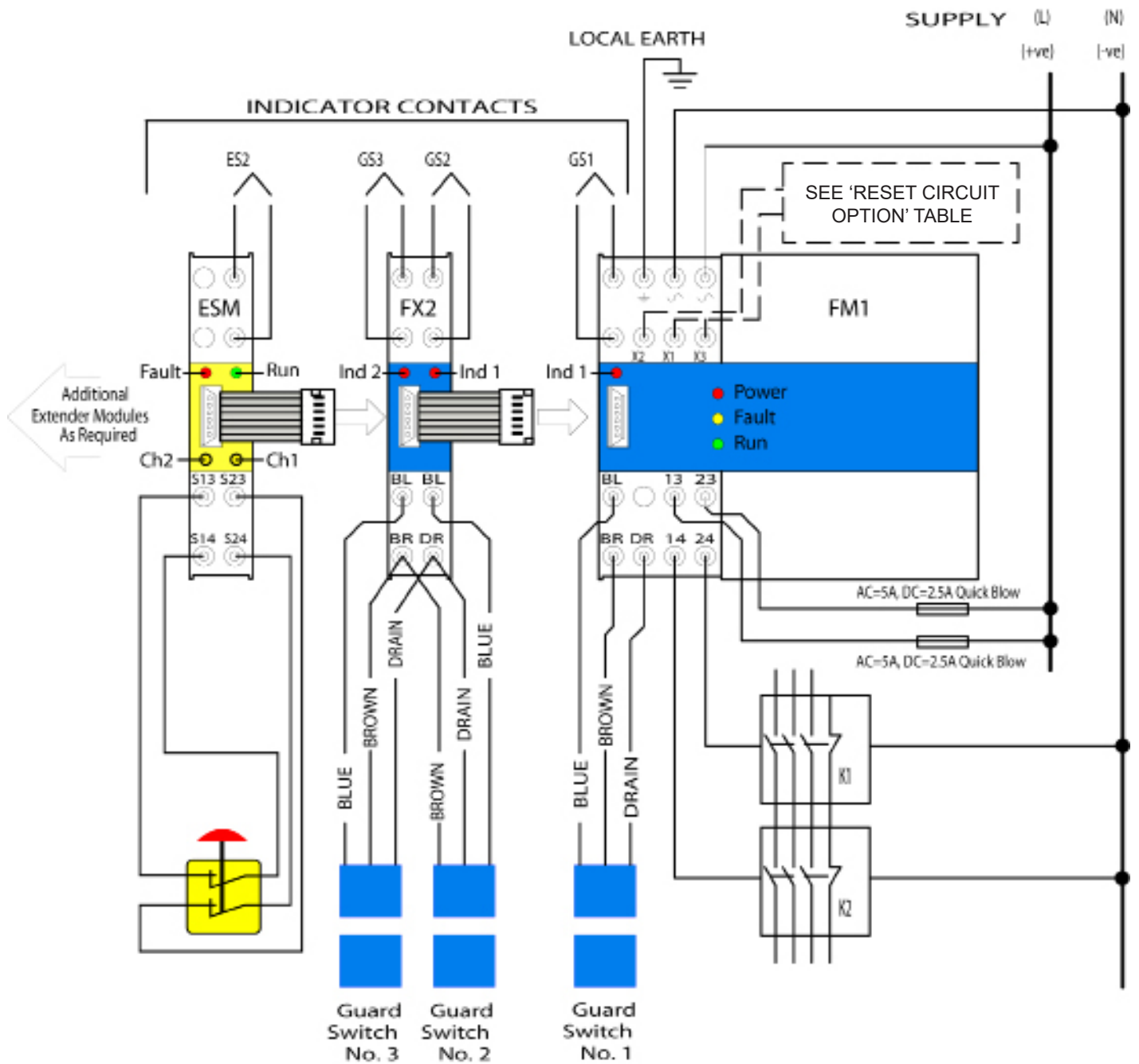

### Note :

1) When the unit is powered, safety switches closed, e'stop's released and the re-set circuit is made the N/O safety outputs will close and the N/C indicator output will be open.

2) When a safety switch is opened, ( the actuator moved away from the switch) or one of the e'stops actuated, the N/O safety outputs will open and the N/C indicator output will be close. LED's on the input module will indicate which safety switch / e'stop is operated.

# DIMENSIONS

**FM1**

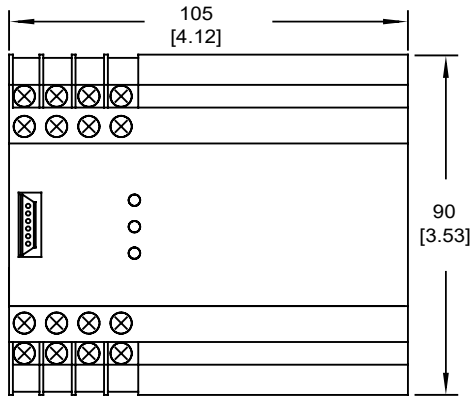

**FX1 / FX2**

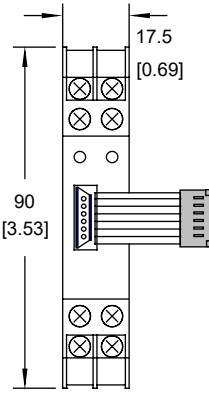

**ESM**

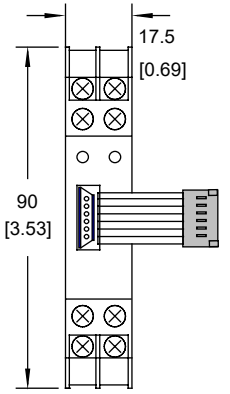

**DNK1**

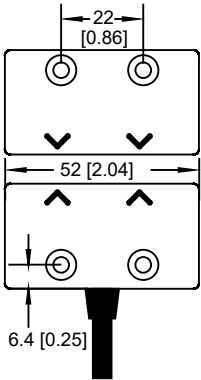

**DNK2**

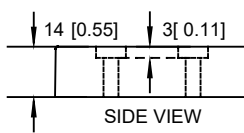
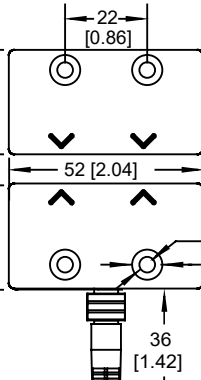

**BMS**

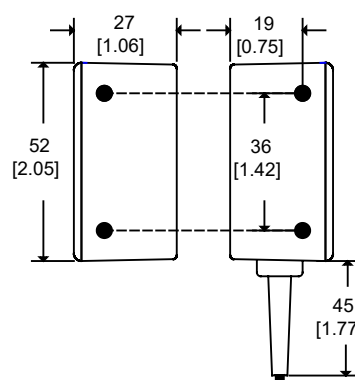

**BMR**

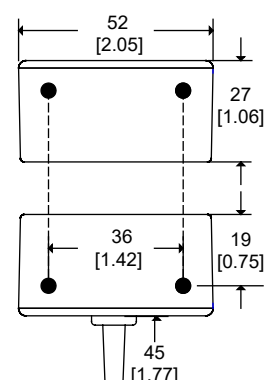

**FMA/SFMA/CMA**

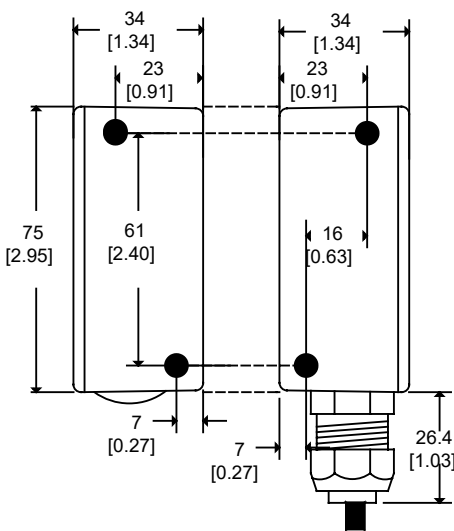

**FMG/SFMG**

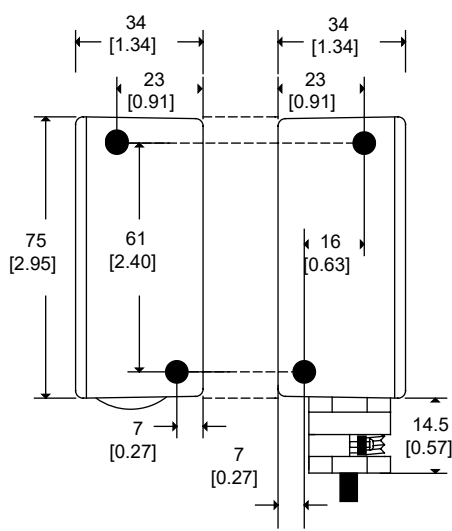

**FMT/SFMT**

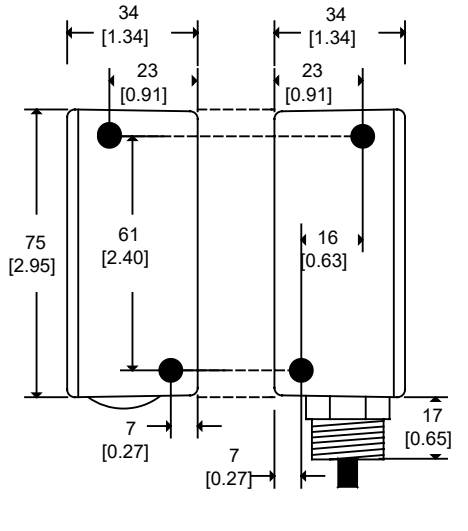

**FM6**

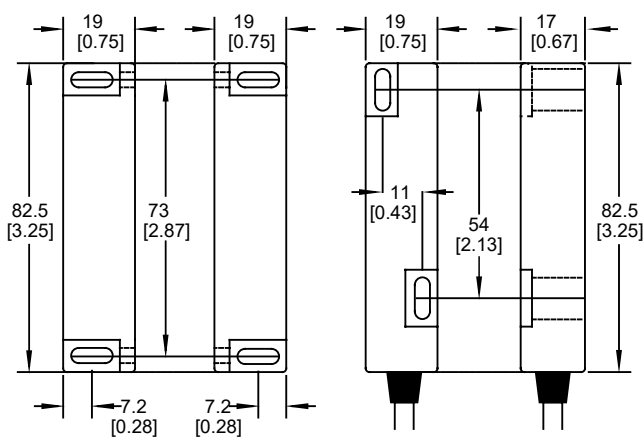

**FM7**

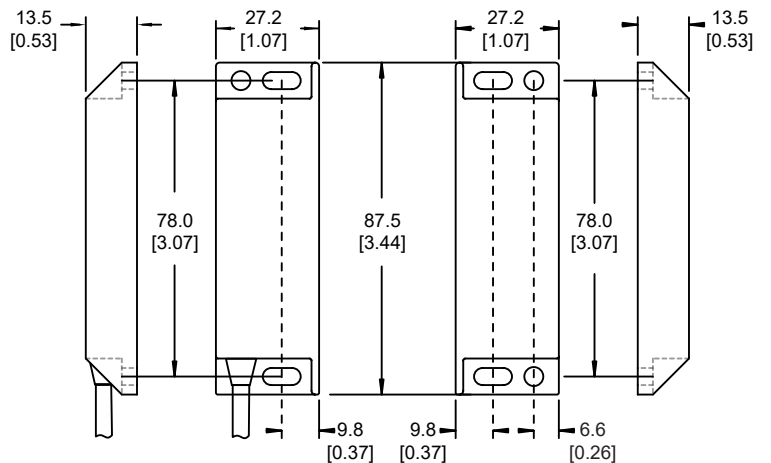

## TECHNICAL SPECIFICATIONS

SAFETY CONTROL UNIT	FM1	FX1/FX2	ESM
Supply nominal voltage	24Vdc 24Vac 110Vac 230Vac		
Nominal power consumption	6VA	3VA	3VA
Safety contacts	2 x N/O		
Output contact rating (max)	4A/230Vac; 2A/24Vdc(Res.)@Cos=1		
Output contact rating (min)	10V/10mA		
Output contact fuse rating	AC=5A; DC=2.5A; Quick blow		
Drop out time	Deactivation by sensor, 13ms		
Internal fuse	500mA Resetable		
Internal fuse recovery time	>2 Seconds		
Indication	LED's - Power, Fault, and Run LED & Volt Free Contact for Safety Switch	LED & Volt Free Contact For each input	LED for each Channel & Volt Free Contact
Indication Contact rating	500mA/30VDC	500mA/30VDC	500mA/30VDC
Max conductor size	2 x 1.5mm stranded with sleeves, 2 x 2.5mm solid	2 x 1.5mm stranded with sleeves, 2 x 2.5mm solid	2 x 1.5mm stranded with sleeves, 2 x 2.5mm solid
Installation group (Control unit)	C in accordance with VDE0110		
Enclosure protection	Housing IP30, Terminals IP20		
Operating temperature	0C to +45C (85% Humidity max)	0C to +45C (85% Humidity max)	0C to +45C (85% Humidity max)
Storage temperature	-20C to +60C	-20C to +60C	-20C to +60C
Housing material	PC-GF, Light Grey (RAL 7035)	PC-GF, Light Grey (RAL 7035)	PC-GF, Light Grey (RAL 7035)
Mounting / Fixing	35mm Symmetric DIN Rail	35mm Symmetric DIN Rail	35mm Symmetric DIN Rail
<b>Utilisation category in accordance with EN 60947-4-1</b>			
Safety contacts : AC1 at 230 V		Imin:10mA.Imax:4A	
Safety contacts : DC1 at 24 V		Imin:10mA.Imax:2A	
<b>Air gap creepage in accordance with EN 60947-1</b>			
Pollution Degree	2		
Overvoltage Category	III		
Rated Insulation Voltage	250V		
Rated Impulse Withstand Voltage	4.0KV		
<b>Vibration In Accordance With EN 60068-2-6</b>			
Weight (AC/DC)	420g/290g	FX1 65g / FX2 75g	
Frequency	10-55Hz		
Amplitude	0.35mm		
<b>Safety Related Data</b>			
PL In accordance with EN ISO 13849-1	PL-e, CAT 4		
SIL CL in accordance with EN IEC 62061	SIL 3		
PFHd in accordance with EN IEC 62061	6.0 x 10 <sup>-9</sup>		
PFH	6.52 x 10 <sup>-9</sup>		
B10d	2000000		
MTTFd	High > 100 Years (Based on usage rate of 360 days/year, 24 Hours/Day, 10 Operations/Hour)		
TM(mission time)	20 Years		
DC	99%		
SFF	99.5%		

SAFETY SWITCHES	F-Type	B-Type	R-Type	Dinky	F6	F7
Pre-wired cables	Pre-wired 3 / 5 or 10 Metre Cables	Pre-wired 3 / 5 or 10 Metre Cables	Pre-wired 3 / 5 or 10 Metre Cables	Pre-wired 3 / 5 or 10 Metre Cables	Pre-wired 3 / 5 or 10 Metre Cables	Pre-wired 3 / 5 or 10 Metre Cables
Quick Disconnect				M8 Quick Disconnect 5 or 15 Metre Cable		
Cable Gland	FMA Anaconda FMG Cord Grip FMT Brass 20mm Thread	BMS Side Exit BMR Rear Exit	RMA Anaconda			
Unique Coding			R-Series - 4 Billion Unique codes			
Operation	Electronic					
Safety Contact Operating Distance	7mm ON / 10mm OFF					
Optimum Gap	1mm					
Dimensions	See page 6					
IP Rating	IP67 / IP69K					
Cable Length	100 Metres max					
Operating temperature	-20 to +50C					
Mounting	Target to target					
Construction	Blue ABS Resin Filled		Orange ABS Resin Filled	Blue ABS Resin Filled		

# ATEX – Declaration of Conformity



## 1) SUBJECT

Equipment and protective F-Series safety switches and Actuators intended for use in potentially Explosive Atmospheres complies with relevant requirements of ATEX - **Directive 2014/34/EU” Encapsulation 'm' / 'tc' electrical apparatus for explosive gas and dust atmospheres”, incorporating EN 60079-0 and EN 60079-18** compliant equipment according to the intended Zones:

Category 3G/Zone 2  
Category 3D/Zone 22

## 2) DESCRIPTION

**2.1 GENERAL** The safety switch, Type FMA from the “F” series, manufactured by Mechan Controls Ltd. It is a type of Machine Guard safety switch and Actuator used for machine interlocking. The switch consisted of the sensor head and the Actuator target block both consist of solid-state electronic circuits, encapsulated into an ABS polymer casing with approximate dimensions 74mm x 33mm x 30mm to provide a fully sealed, IP67 & IP69K, sensor which can withstand the most arduous of conditions. Water, dust, oil, machine vibration and even steam cleaning have no effect on their performance. The encapsulant is a 50:50 mixture of epoxy resin and micron glass beads. Two through holes were provided for clamping/Fixing into machine guards. The sensor head was provided with 100m maximum of moulded-in, PVC insulated, sheathed three-core cable. A gland is fitted into the enclosure to allow the attachment of flexible metal conduit for protection of the cable.

The safety switch is operated by a control module which supplied 24 V dc at 2 mA to the switch. This Control module FM1/FX1/FX2/EM1/ESM must be installed in a safe area.

Types FMG and FMT differ only in terms of the type of connection gland fitted.

**2.2 IDENTIFICATION** The enclosures were marked as follows:

Mechan Controls  
Safety Sensor EX-Series  
Part Number : FMA, FMG, FMT



**F-SERIES  
HAZARDOUS AREA  
SAFETY SENSOR  
Ex-SERIES**

**II 3G Ex mc IIA T6 Gc  
II 3D Ex tc IIIC T80°C Dc  
-20°C<Ta<+60°C**

We hereby declare that the products identified above conform to the relevant ATEX – Directive 2014/34/EU Requirements and to the following EC Directive(s) Machinery Directive (2006/42/EC), EMC Directive (2004/108/EC), Low Voltage Directive(2006/95/EC).

### NOTES

In the interest of product development specifications are subject to change without notice.

It is the responsibility of the user to ensure compliance with any acts or by-laws in place.

All information regarding Mechan equipment is believed to be accurate at the time of printing. Responsibility cannot be accepted for errors or omissions. All information regarding Mechan equipment is believed to be accurate at the time of printing. Responsibility cannot be accepted for errors or omissions.

### Declaration of Conformity

Please contact Mechan Controls.

Document Number : 327-400-Iss5

### Maintenance

It is recommended to check the safe operation of the of the switches and look for signs of damage or excessive wear on a weekly basis. Damaged units should be replaced or returned to the manufacturer for repair where practical.



**MECHAN CONTROLS LTD**

14/16 SEDDON PLACE, STANLEY INDUSTRIAL ESTATE  
SKELMERSDALE , LANCASHIRE WN8 8EB

UNITED KINGDOM

Telephone :+44(0)1695 722264

web : [www.mechancontrols.co.uk](http://www.mechancontrols.co.uk)